



Florida Department of Environmental Protection

Bob Martinez Center
2600 Blair Stone Road
Tallahassee, Florida 32399-2400

Charlie Crist
Governor

Jeff Kottkamp
Lt. Governor

Michael W. Sole
Secretary

June 12, 2009

William Parkes
Cliff Berry Inc
PO Box 13079
Fort Lauderdale, FL 33316- 0100

BE IT KNOWN THAT

Cliff Berry Inc
5218 Saint Paul St
Tampa, FL 33619- 6118

IS HEREBY REGISTERED AS A USED OIL

Transporter, Transfer Facility, Processor, Marketer, Filter Transporter,
Filter Transfer Facility

pursuant to Chapter 62-710, Florida Administrative Code (F.A.C)
The Department of Environmental Protection hereby issues
Registration Number **FLR000013888** on June 12, 2009
Insurance Carrier: **GREENWICH INSURANCE**

This registration will expire on 06/30/2010

This certificate documents receipt of your annual registration
and annual report. It shall be displayed in a prominent place
at your facility. This certificate and your cancelled check
are your receipts.

A handwritten signature in black ink that reads "Aprilia Graves". The signature is written in a cursive, flowing style.

Aprilia Graves
Environmental Specialist IV
Hazardous Waste Regulation Permitting



8700-12FL - FLORIDA NOTIFICATION OF REGULATED WASTE ACTIVITY

DEP Waste Management Division-HWRS, MS4560
2600 Blair Stone Rd. Tallahassee, FL 32399-2400
(850) 245-8772

Date Received (for FDEP Official Use Only)

EPA ID FLR0000013888

1. Reason for Submittal

Mark 'X' in correct box:

- To provide initial notification (to obtain an EPA ID Number for hazardous waste, universal waste, or used oil activities).
To provide subsequent notification (to update status and facility identification information).
Is this the final notification (see instructions) for the facility?

2. Facility or Business Name

CLIFF BERRY, INC. - TAMPA FACILITY

FEID No.

650511114

3. Facility Operator (List additional Operators in the comments section).

Name of Operator:

CLIFF BERRY, INC. (CBI)

New Operator

Date became Operator: 1-1-2000 mm dd yy

Street or P.O. Box:

P.O. Box 13079

Phone Number:

(954) 763-3390

City or Town:

FORT LAUDERDALE

State:

FLORIDA

Zip Code:

33316

Operator Type:

- Private Federal Municipal State Other

4. Facility Physical Location Information

Physical Street Address:

5218 ST. PAUL STREET

City or Town:

TAMPA

State:

FL

Zip Code:

33619

County:

Choose - HILLSBOROUGH

If available, please attach a map or sketch of the facility boundaries. SEE ATTACHED SITE PLAN

Latitude:

27 55 10. N d d m m s s . ssss

Longitude:

82 23 45. W d d m m s s . ssss

Method:

Datum:

5. Facility North American Industry Classification System (NAICS) Code(s)

A. 562219 (SEE NOTE IN COMMENTS)

B.

C.

D. Initials

6. Facility or Business Mailing Address

Street Address or P.O. Box:

P.O. Box 13079



Date

City or Town:

FORT LAUDERDALE

State:

FL

Zip Code:

33316

7. Facility or Business Contact Person

First Name:

WILLIAM

Last Name:

PARKES, JR.

Title: MANAGER REGULATORY AFFAIRS

Phone Number:

(954) 763-3390

Extension:

124

E-Mail: BPARKES@CLIFF BERRY INC. COM

Street or P.O. Box:

P.O. Box 13079

City or Town:

FORT LAUDERDALE

State:

FL

Zip Code:

33316

8. Real Property (Land) Owner of the Facility's Physical Location (List additional real property owners in the comments section.)

Name of Real Property (Land) Owner:

C-2 HOLDINGS, INC.

New Owner

Date became Owner: 1-1-2000 mm dd yy

Street or P.O. Box:

P.O. Box 350123

Phone Number:

(954) 763-3390

City or Town:

FORT LAUDERDALE

State:

FL

Zip Code:

33335

Owner Type:

- Private Federal Municipal State Other

9. Type of Regulated Waste Activity (Mark 'X' in all that apply):

A. Hazardous Waste Activities:

For Items 2 through 7, mark 'X' in all that apply.

(1) Generator of Hazardous Waste

- (Choose only one of the following three categories.)
- a. Large Quantity Generator (LQG):
Generates in any calendar month 1,000 kilograms or greater per month (kg/mo) (2,200 lbs.) of *non-acute* hazardous waste; or Greater than 1 kg (2.2 lbs) of *acute* hazardous waste
 - b. Small Quantity Generator (SQG):
Generates in any calendar month greater than 100kg/mo but less than 1,000 kg/mo (>220 to <2,200 lbs.) of *non-acute* hazardous waste and/or 1 kg (2.2 lbs) or less of *acute* hazardous waste
 - c. Conditionally Exempt SQG (CESQG):
Generates in any calendar month 100 kg/mo or less (220 lbs.) of *non-acute* hazardous waste and 1 kg (2.2 lbs) or less of *acute* hazardous waste

In addition, indicate other generator activities that apply.

- d. United States Importer of hazardous waste
- e. Mixed Waste (hazardous and radioactive) Generator

(2) Treater, Storer, or Disposer of Hazardous Waste

(at your facility) Note: A hazardous waste permit may be required for this activity.

- a. Operating Commercial TSD
- b. Operating Non-commercial TSD
- c. Non-operating: Postclosure or Corrective Action Permit or Consent Order (HSWA, etc.)

(3) Recycler of Hazardous Waste (at your facility)

Specify: Commercial; Non-Commercial.
A permit is required for storage prior to recycling.

(4) Exempt Boiler and/or Industrial Furnace

- a. Small Quantity On-site Burner Exemption
- b. Smelting, Melting, and Refining Furnace Exemption

(5) Person Authorized to Manage Conditionally Exempt Waste Generated at Other Facilities -

Choose this management activity ONLY if you attach EITHER a copy of your application for such authorization OR the authorization you received from FDEP.

(6) Underground Injection Control - Mark an 'X' even if the UIC well at your facility does not receive hazardous waste.

(7) Transporter of Hazardous Waste [Note: A Certificate of Liability Insurance is required along with this registration.]

Registration must be renewed annually. a. For own waste only b. For commercial purposes

c. Hazardous Waste Transporter Insurance Information

Insurance Company *XL SPECIALTY INSURANCE COMPANY*
 Address *1990 N. CALIFORNIA BLVD, SUITE 740*
WALNUT CREEK, CALIFORNIA 94596
 Contact _____ Telephone _____
 Policy Number *AEC 000 638 909* Expiration date *12/31/09*

d. **Transportation Mode** Air Rail Highway Water Other - specify _____

e. **Hazardous Waste Transfer Facility:** Storage Volume _____

Initial notification

The following items are required to be submitted with the initial notification for a transfer facility [Rule 62-730.171(3), Florida Administrative Code (F.A.C.)]:

- Certification by a responsible corporate officer of the transporter that the proposed location satisfies the criteria of Section 403.7211(2), Florida Statutes (F.S.) [Rule 62-730.171(3)(a)1., F.A.C.]
- Evidence of the transporter's financial responsibility [Rule 62-730.171(3)(a)3., F.A.C.]
- A brief general description of the transfer facility operations [Rule 62-730.171(3)(a)4., F.A.C.]
- A copy of the facility closure plan [Rule 62-730.171(3)(a)5., F.A.C.]
- A copy of the contingency and emergency plan [Rule 62-730.171(3)(a)6., F.A.C.]
- A map or maps of the transfer facility [Rule 62-730.171(3)(a)7., F.A.C.]
- Notification of changes in above items**
- Annual update notification**

B. Universal Waste (UW) Activities (Mark 'X' in all that apply) ("accumulated" means at any one time):

- Large Quantity Handler (LQH) = 5,000 kg (11,000 lb) or more of any combination of UW accumulated
 - Small Quantity Handler (SQH) = always less than 5,000 kg accumulated
 - Mercury-containing devices LQH = 100 kg (220 lb) or more accumulated by for-hire handler
 - Mercury-containing devices SQH = less than 100 kg accumulated by for-hire handler
 - Mercury-containing lamps LQH = 2,000 kg (4400 lbs/8,000 lamps) or more accumulated by for-hire handler
 - Mercury-containing lamps SQH = less than 2,000 kg (8,000 lamps) accumulated by for-hire handler
- [Note: 4 lamps = 1 kg, 62-737.200(10)]
- Pharmaceuticals LQH = 5,000 kg or more of universal pharmaceutical waste (UPW) accumulated
 - Pharmaceuticals LQH = more than 1 kg (2.2 lb) of acutely hazardous ("P-listed") pharmaceutical waste accumulated
 - Pharmaceuticals SQH = always less than 5,000 kg of UPW and always 1 kg or less of acutely hazardous UPW accumulated

(1) For those Managing	Generate/ Accumulate	Transport (see note in instructions)	Handle at Transfer Facility	(2) Enter your estimate of the maximum amount (in pounds) of each type of UW on site or transported at any one time.
a. Batteries	<input type="checkbox"/>	<input type="checkbox"/>	<input checked="" type="checkbox"/>	<i>3,000</i>
b. Pesticides	<input type="checkbox"/>	<input type="checkbox"/>	<input type="checkbox"/>	
c. Pharmaceuticals	<input type="checkbox"/>	<input type="checkbox"/>	<input checked="" type="checkbox"/>	<i>50</i>
d. Mercury Containing Devices	<input type="checkbox"/>	<input type="checkbox"/>	<input checked="" type="checkbox"/>	<i>100</i>
e. Mercury Containing Lamps	<input type="checkbox"/>	<input type="checkbox"/>	<input checked="" type="checkbox"/>	<i>2,000</i>

(3) Mercury Recovery and/or Reclamation Facility [Chapter 62-737, F.A.C.] Note: A hazardous waste permit is required for this activity. [Rule 62-737.800, F.A.C.]

(4) Reverse Distributor of UW Pharmaceuticals Lamps Devices

(5) Destination Facility for UW Note: for this activity, a facility must treat, dispose or recycle a UW. A permit is required for storage prior to recycling.

C. Used Oil Activities:

(1) Used Oil Transporter - indicate type(s) of activity(ies):

- a. Transporter
- b. Transfer Facility
- (2) Collection Center
- (3) Used Oil Processor (A permit is required for this activity.)
- (4) Off-Specification Used Oil Burner
- (5) Used Oil Fuel Marketer
- (6) Used Oil Filter
 - a. Transporter
 - b. Transfer Facility
 - c. Processor
 - d. End User

(8) Specific Certification to be signed by all Used Oil Transporters

I certify as a Used Oil Transporter that the training program and financial responsibility required under Section 62-710.600, F.A.C., are in place, current and being adhered to. If any modifications have been made to the originally approved training program, they are explained in attachments to this registration form. Evidence of financial responsibility is demonstrated by the attached Used Oil Transporter Certificate of Liability Insurance, DEP form 62-710.901(4), F.A.C.

Cliff Berry, II
Signature of Authorized Person

CLIFF BERRY, II
Print Name of Authorized Person

(7) Used Oil Transporters, Transfer Facilities, Collection Centers, Off-Specification Burners and Marketers must pay an annual \$100 registration fee. Used Oil Processors are exempt from this fee. If applicable, enclose a check or money order, in the amount of \$100, payable to Florida Department of Environmental Protection.
 A check is enclosed.

(9) The records required under the provisions of Rule 62-710.510, F.A.C., are kept at (check one):
 our mailing (business) address
 The site (facility) address

D. Other State Regulated Waste Activities: **Petroleum Contact Water (PCW) Handler** [Chapter 62-740, F.A.C.]
 Note: A water facility permit may be required for this activity.

10. Waste Codes for Federally Regulated Hazardous Wastes: List the waste codes of the Federal hazardous wastes handled at your facility. List them in the order they are presented in the regulations (e.g., D001, D003, F007, U112). Hazardous waste transporters list codes routinely or usually transported. Use an additional page if more spaces are needed.

1	2	3	4	5	6	7
8	9	10	11	12	13	14
15	16	17	18	19	20	21
22	23	24	25	26	27	28

(SEE ATTACHED SHEET)

11. Other Status Changes (Mark 'X' in all that apply):

A. Non-Handler of Regulated Waste at This Facility

- (1) Business no longer generates, transports, treats, stores, or disposes of hazardous waste
- (2) Waste generated by business has been delisted.
- (3) Other (explain) _____

B. Facility Closed

- (1) Closed at this location and **moved or moving** to another - submit a new Form 8700-12FL for the new location if you will be handling regulated waste there.
- (2) Out of Business - Business closed on _____ (Date). Please provide a contact person, mailing address, and phone number where you can be reached after closing.

Contact _____ Phone _____
 Address _____
 City, State, Zip _____

C. Property Tax Default

D. Petition for Bankruptcy Protection

12. Certification: I certify under penalty of law that this document and all attachments were prepared under my direction or supervision in accordance with a system designed to assure that qualified personnel properly gather and evaluate the information submitted. The information submitted is, to the best of my knowledge and belief, true, accurate, and complete. I am aware that there are significant penalties for submitting false information, including the possibility of fine and imprisonment for knowing violations. If I have notified as a transfer facility, I am aware that transfer facilities must comply with the requirements of Rule 62-730.171, FAC, and Rule 62-730.182, FAC.

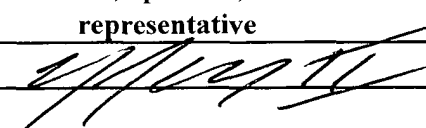
Signature of owner, operator, or an authorized representative	Print Name and Title	Date Signed (mm-dd-yyyy)
<i>X</i> 	<i>CLIFF BERRY, II, PRESIDENT</i>	<i>04/15/2009</i>

If the person who filled in this form is not the Facility Contact or Operator, please complete the information below:

WILLIAM E. PARKES, JR. (Name of person completing this form) *(954) 763-9390* (Phone Number) *BPARKES@CLIFFBERRYINC.COM* (E-mail Address)

13. Comments:

NOTE: CBE USES SIC CODE 1799 FOR OSHA 300 LOGS

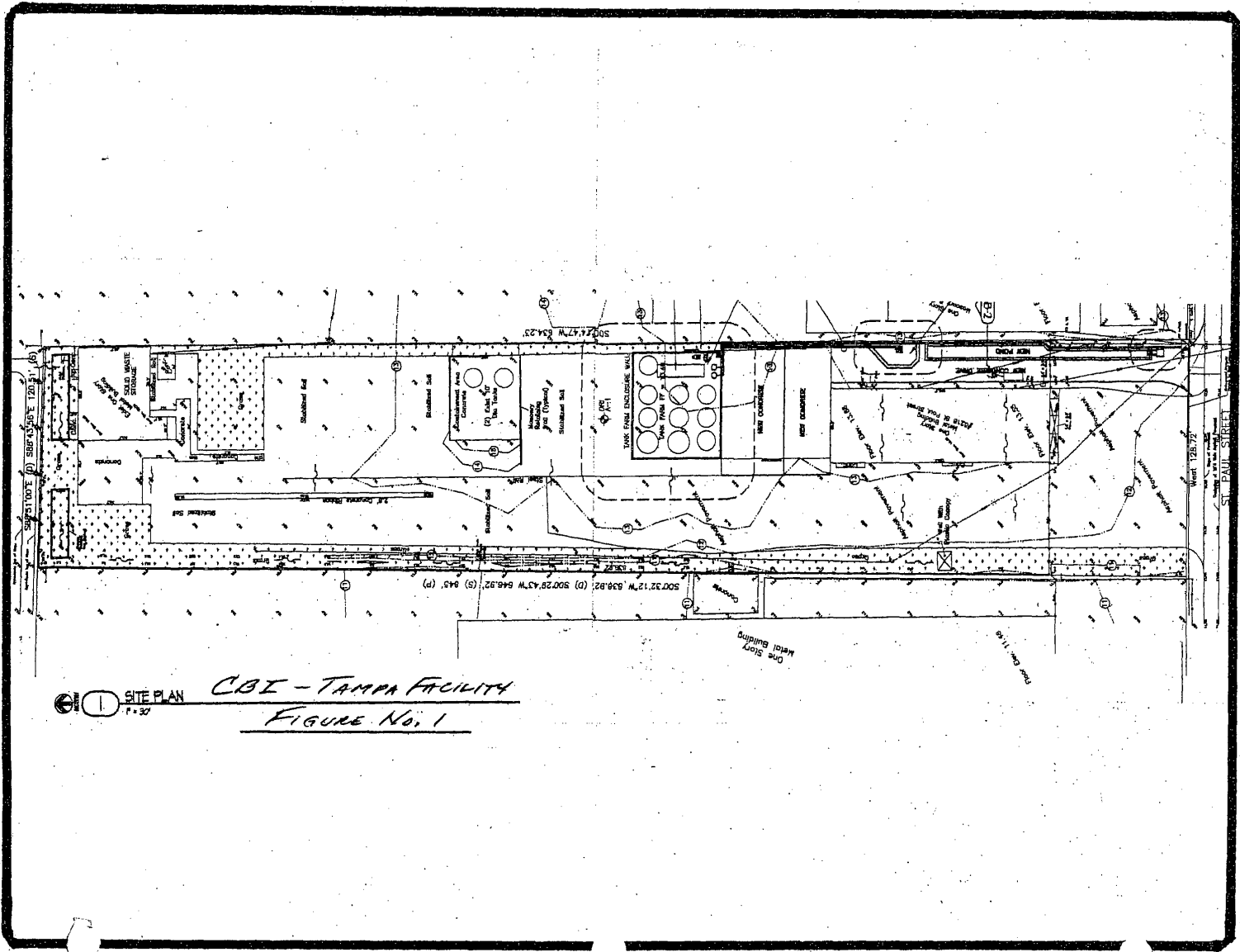

SITE PLAN
CBI - TAMPA FACILITY
FIGURE No. 1

paragranal

D001	F032	P068	U001	U066	U126	U190	U365
D002	F034	P070	U002	U067	U127	U191	U366
D003	F035	P071	U003	U068	U128	U192	U367
D004	F037	P072	U004	U069	U129	U193	U372
D005	F038	P074	U005	U070	U130	U194	U373
D006	F039	P075	U007	U071	U131	U196	U375
D007	K001	P077	U008	U072	U132	U197	U376
D008	P001	P082	U009	U073	U134	U200	U377
D009	P002	P084	U010	U074	U136	U201	U378
D010	P003	P085	U011	U076	U137	U202	U379
D011	P004	P087	U012	U077	U138	U203	U381
D012	P005	P088	U014	U078	U140	U204	U383
D013	P007	P089	U015	U079	U141	U206	U384
D014	P008	P092	U016	U080	U142	U207	U385
D015	P010	P093	U017	U081	U143	U208	U386
D016	P011	P094	U018	U082	U144	U209	U387
D017	P012	P097	U019	U083	U145	U210	U389
D018	P013	P098	U021	U084	U146	U211	U390
D019	P014	P099	U022	U085	U147	U212	U391
D020	P015	P101	U024	U086	U148	U213	U392
D021	P016	P102	U025	U087	U149	U214	U393
D022	P018	P103	U026	U088	U150	U215	U394
D023	P020	P104	U027	U089	U151	U126	U395
D024	P021	P105	U028	U090	U152	U218	U396
D025	P023	P106	U029	U091	U154	U219	U400
D026	P024	P108	U030	U092	U155	U220	U401
D027	P026	P109	U031	U093	U156	U221	U402
D028	P027	P110	U032	U094	U157	U222	U403
D029	P028	P111	U034	U095	U158	U226	U404
D030	P029	P113	U035	U097	U159	U227	U407
D031	P030	P114	U036	U098	U161	U228	U409
D032	P034	P115	U037	U099	U162	U230	U410
D033	P036	P116	U038	U101	U164	U231	U411
D034	P037	P118	U039	U102	U165	U232	
D035	P038	P119	U041	U103	U166	U233	
D036	P039	P120	U042	U105	U167	U235	
D037	P040	P121	U044	U106	U168	U236	
D038	P041	P123	U045	U107	U169	U237	
D039	P043	P127	U046	U108	U170	U238	
D040	P044	P128	U047	U109	U171	U239	
D041	P045	P185	U048	U110	U172	U240	
D042	P046	P188	U049	U111	U173	U242	
D043	P047	P189	U050	U112	U174	U243	
F001	P048	P190	U051	U113	U176	U244	
F002	P049	P191	U052	U114	U177	U246	
F003	P050	P192	U053	U115	U178	U247	
F004	P051	P194	U055	U116	U179	U248	
F005	P054	P196	U056	U117	U180	U271	
F006	P057	P197	U057	U118	U181	U277	
F007	P058	P198	U058	U119	U182	U278	
F008	P059	P199	U059	U120	U183	U279	
F009	P060	P201	U060	U121	U184	U280	
F010	P062	P202	U061	U122	U185	U328	
F011	P064	P203	U062	U123	U186	U353	
F012	P066	P204	U063	U124	U187	U359	
F019	P067	P205	U064	U125	U188	U364	

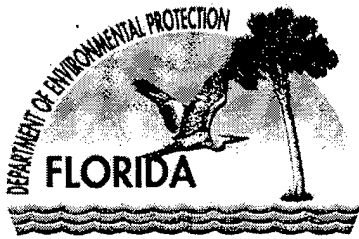

Florida Department of Environmental Protection

Bob Martinez Center
2600 Blair Stone Road
Tallahassee, Florida 32399-2400

Charlie Crist
Governor

Jeff Kottkamp
Lt. Governor

Michael W. Sole
Secretary

UNIVERSAL WASTE LAMP AND DEVICE TRANSPORTER AND TRANSFER FACILITY INFORMATION CHECKLIST

The Department requires that all universal waste lamp and device transporters and transfer facilities registered under Rule 62-737.400, F.A.C., complete and sign this Information Checklist. This information will be used to evaluate compliance with subparagraph 62-737.400(1)(b), F.A.C. **Your transporter registration will not be issued until you complete and return the checklist.** Handlers that are not engaging in transport activities need not complete this form.

CLIFF BERRY, INC. - TAMPA FACILITY FL0000015555
(Facility Name) (EPA id)

5218 ST. PAUL STREET TAMPA, FLORIDA 33619
(Street Address) (City) (State) (Zip)

(954) 763-3390 (954) 763-8375 BPARKES@CLIFFBERRYINC.COM
(Phone) (Fax) (E-mail)

Section 1: For all transporters and transfer facilities (in-state and out-of-state).

Complete all sections and check all boxes that apply.

1. Estimated number of LAMPS handled during the last calendar year. 10,000
 Types: Fluorescent HID
2. Estimated number of DEVICES handled during the last calendar year. 100
 Types: Thermostats Electric Switches/Relays
 Thermometers Manometers Other
3. Estimated weight of DEVICES handled during the last calendar year. 150 lb.
4. Estimated number of lamps or devices you shipped to each lamp recycling facility. Check the boxes for lamps (L) or devices (D). Give the facility name, location, and contact information.

Number	L	D	Facility Name	City	State	Phone
<u>ALL</u>	<input checked="" type="checkbox"/>	<input checked="" type="checkbox"/>	<u>AERC RECYCLING</u>	<u>W. MELBOURNE,</u>	<u>FL</u>	<u>(321) 952-1516</u>
	<input type="checkbox"/>	<input type="checkbox"/>				
	<input type="checkbox"/>	<input type="checkbox"/>				
	<input type="checkbox"/>	<input type="checkbox"/>				
	<input type="checkbox"/>	<input type="checkbox"/>				
	<input type="checkbox"/>	<input type="checkbox"/>				

CLIFF BERRY, II
Print Name of Authorized Agent

[Signature]
Signature of Authorized Agent

4/15/09
Date



Florida Department of Environmental Protection

Bob Martinez Center
2600 Blair Stone Road
Tallahassee, Florida 32399-2400

Charlie Crist
Governor

Jeff Kottkamp
Lt. Governor

Michael W. Sole
Secretary

Section 2: For out-of-state transporters and transfer facilities only

1. Is any environmental agency in your state aware of your activities as a transporter or transfer facility for universal waste lamps and devices in Florida?

Yes

No

2. If you have not already done the following in previous years, please enclose some written verification from that environmental agency that they are aware of your activities as a transporter for universal waste lamps and devices in Florida and in your state. This verification can be in the form of a letter to you or to the Department, a registration, a permit, etc.

Submitted Previously

Submitted in What Year? _____

CLIFF BEAM, II
Print Name of Authorized Agent

[Signature] 4/15/09
Signature of Authorized Agent Date

Complete, sign and return this checklist along with your registration form to:

EPA ID Notification Coordinator
Hazardous Waste Regulation Section MS 4560
Department of Environmental Protection
2600 Blair Stone Road
Tallahassee, Florida 32399-2400

Your transporter registration will not be issued until you complete and return this checklist.

QUESTIONS OR COMMENTS?

If you have any questions or comments, please contact Laurie Tenace at (850) 245-8759 or via e-mail at laurie.tenace@dep.state.fl.us.

Thank you for your cooperation in providing this information.

TransChkl.doc

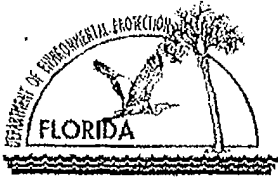

Department of Environmental Protection

FDEP MS 4555 2600 Blair Stone Road Tallahassee, Florida 32399-2400

DEP Form #62-710.900(15)
Form Title Certificate of Liability Insurance
Used Oil Transporters
Effective Date June 2, 2005

Certificate of Liability Insurance
Used Oil Transporters

Please Print or Type Form

1. Greenwich Insurance Company, (the Insurer), 1990 N. California Blvd., Suite 740 Walnut Creek, CA 94596
(Name of the Insurer) (Address of the Insurer)

hereby certifies that it has issued liability insurance covering bodily injury and property damage for sudden accidental

occurrences to Cliff Berry, Inc., (the Insured), 3400 SE 9th Avenue, Dania Beach, FL 33316
(Name of the Insured) (Address of the Insured)

whose EPA Identification number is FLR000083071 in connection with the insured's obligation to demonstrate
financial responsibility under Florida Administrative Code Rule 62-710.600(2)(d). The insurance is primary and the company
shall be liable for amounts up to \$ 1,000,000 less the deductible or retention of \$ 10,000

for each accident exclusive of legal defense costs. If a deductible or retention is applied, its amount may not exceed 10% of
the equity of the Insured. This coverage is provided under policy number AEC000638908, issued on

12/31/08. The expiration date of said policy is 12/31/09 or the annual renewal date
(Date) (Date)

is 12/31/09.

2. The insurer further certifies the following with respect to the insurance described in Paragraph 1:

- a. Bankruptcy or insolvency of the insured shall not relieve the Insurer of its obligations under this policy.
b. The Insurer is liable for the payment of amounts within any deductible applicable to the policy, with a right of reimbursement by the Insured for any such payment made by the insurer.
c. Whenever requested by the Secretary (or designee) of the Florida Department of Environmental Protection (FDEP), the Insurer agrees to furnish to the Department a signed duplicate original of the policy and all endorsements.
d. Cancellation of the insurance, whether by the Insurer or the Insured or by any other termination of the insurance (e.g., expiration or non-renewal), will be effective only upon written notice and only after the expiration of thirty-five days (35) days after a copy of such written notice is received by the Secretary of the FDEP as evidence by certified mail return receipt.
e. The Insurer shall not be liable for the payment of any judgment or judgments against the Insured for claims resulting from accidents which occur after the termination of the insurance described herein, but such termination shall not affect the liability of the Insurer for the payment of any such judgments resulting from accidents which occur during the time the policy is in effect.

I hereby certify that the Insurer is licensed to transact the business of insurance, or eligible to provide insurance as an excess or surplus lines insurer, in one or more States, including Florida.

Mike Bernath
(Signature of Insurer or Authorized Representative)

Authorized Representative of

Mike Bernath
(Type Name)

Greenwich Insurance Company
(Name of Insurer)

Senior Underwriter
(Title)

520 Eagleview Blvd., Exton, PA 19341
(Address of Representative)

DEP Form	#62-710.900(15)
Form Title	Certificate of Liability Insurance Used Oil Transporters
Effective Date	June 2, 2005

**Chapter 62-710.600, Florida Administrative Code
Certification of Used Oil Transporters**

(d) Demonstrate, and annually verify, proof of liability insurance, or other means of financial responsibility, for any liability which may be incurred in the transport of used oil. Such financial responsibility shall cover sudden and accidental occurrences involving bodily injury and property damage in the amount of at least \$100,000 Combined Single Limit.

1. The \$100,000 Combined Single Limit is the minimum amount of financial responsibility that each used oil transporter must demonstrate. Depending on vehicle size and weight, other restrictions and financial responsibility requirements may be imposed by the Federal or State Departments of Transportation or other agencies.

2. The financial responsibility required in this paragraph may be established by:

(a) Evidence of liability insurance, either on a claim made or an occurrence basis, with or without a deductible (with deductible, if any, to be on a per occurrence or per accident basis and not to exceed ten percent of the equity of the business), using DEP Form 701.900(15). An ACORD form will only be accepted for renewal of a policy with the same carrier; or

(b) Evidence of self-insurance provided by the chief financial officer of the company. see attached insurance papers.

Any questions concerning this form may be referred to the Used Oil Coordinator, MS 4555, Florida Department of Environmental Protection, 2600 Blair Stone Road, Tallahassee, FL 32399-2400, Phone (850) 488-0300, e-mail: richard.neves@dep.state.fl.us

STATE OF FLORIDA

HAZARDOUS WASTE TRANSPORTER CERTIFICATE OF LIABILITY INSURANCE

1. XL Specialty Insurance Company
(Name of Insurer)

(the "Insurer"), of 1990 N. California Blvd., Ste 740, Walnut Creek, CA 94596
(Address of Insurer)

hereby certifies that it has issued liability insurance covering bodily injury and property damage including environmental restoration for sudden accidental occurrences to

Cliff Berry, Inc.
(Name of Insured)

(the "Insured"), of 3400 SE 9th Avenue, Dania Beach, FL 33316
(Address of Insured)

in connection with the insured's obligation to demonstrate financial responsibility under Florida Administrative Code Rule 62-730.170. The coverage applies at:

<u>EPA/DEP I.D. No.</u>	<u>Name</u>	<u>Location</u>
FLR000083071	Cliff Berry, Inc.	3033 NW North River Drive Miami, FL 33142

(If coverage is for multiple facilities, identify each facility insured.)

This insurance is primary and the company shall not be liable for amounts in excess of \$ 1,000,000 for each accident, exclusive of legal defense costs. The coverage is provided under policy number AEC000638909, issued on 12/31/08.
(date)

The effective date of said policy is 12/31/08 and the expiration date of said policy is 12/31/09.
(date)

This insurance is excess and the company shall not be liable for amounts in excess of \$ 5,000,000 for each accident in excess of the underlying limit of \$ 1,000,000 for each accident, exclusive of legal defense costs. The coverage is provided under policy number UEC00063909, issued on 12/31/08. The effective date of
(date)

said policy is 12/31/08 and the expiration date of said policy is 12/31/09.
(date)

2. The Insurer further certifies the following with respect to the insurance described in Paragraph 1:

(a) Bankruptcy or insolvency of the insured shall not relieve the Insurer of its obligations under the policy.

- (b) The Insurer is liable for the payment of amounts within any deductible applicable to the policy, with a right of reimbursement by the insured for any such payment made by the Insurer.
- (c) Whenever requested by the Secretary (or designee) of the Florida Department of Environmental Protection (FDEP), the Insurer agrees to furnish to the Department a signed duplicate original of the policy and all endorsements.
- (d) Cancellation of the insurance, whether by the Insurer or the Insured and any other termination of the insurance (e.g., expiration, non-renewal), will be effective only upon written notice and only after the expiration of thirty (30) days after a copy of such written notice is received by the Secretary of the FDEP as evidenced by certified mail return receipt.
- (e) The Insurer shall not be liable for the payment of any judgment or judgments against the Insured for claims resulting from accidents which occur after the termination of the insurance described herein, but such termination shall not affect the liability of the Insurer for the payment of any such judgment or judgments resulting from accidents which occur during the time the policy is in effect.

I hereby certify that the Insurer is licensed to transact the business of insurance, or eligible to provide insurance as an excess or surplus lines insurer, in one or more States including Florida.

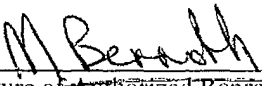

(Signature of Authorized Representative of Insurer)

Michael Bernath

(Typed name) (Social Security Number)

Senior Underwriter

(Title)

Authorized Representative of

XL Specialty Insurance Company, c/o XL Environmental, Inc.

(Name of Insurer)

P.O. Box 636, 520 Eagleview Blvd., Exton, PA 19341

(Address of Representative)

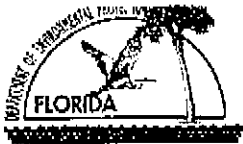

Annual Report by Used Oil and Used Oil Filter Handlers*

(*Handlers are any persons subject to the registration requirements of rule 82-710.500 and 62-710.850, F.A.C. [See Section A, Box 5 below])
 for reporting period January 1, 2008 through December 31, 2008
 Use the information recorded in your Record Keeping Form (62-710.901(2)) or equivalent to complete this document

SECTION A TO BE COMPLETED BY ALL REGISTERED PERSONS

1. Company Name: CLIFF BERRY, INC (TAMPA) 2. Telephone No. (954) 763-3390
 Site Address: 5218 ST PAUL STREET
TAMPA, FL 33619 3. EPA ID No. FLR 000 013888

Check box if any of the above items (1-3) have changed since your last registration

4. Name of person preparing report (please print) GARY GIBSON
 Title MANAGER Phone number (if different from #2. above) () _____

5. Type of operation (check as many as apply to your operations)
 Used Oil: Transporter Transfer Facility Collection Center/Aggregation Point Processor Marketer
 Burner (of off-specification used oil)
 Used Oil Filter: Transporter Transfer Facility Processor End User

SECTION B USED OIL (TO BE COMPLETED BY ALL REGISTERED USED OIL HANDLERS. USED OIL FILTER HANDLERS SEE SECTION C)

	Automotive	Industrial	Mixed	Total
1. Amount (in gallons) of Used Oil and Oily Wastes collected				
a. In Florida.....	492135	2650975	1760	3184870
b. From out of state.....				0
c. Beginning Inventory.....				45398
d. Total (sum of totals from Lines a + b + c).....				3230268

2. Amount (in gallons) of Used Oil and Oily Wastes Managed

N - Not an end use, transferred to another facility for storage or processing.....

O - Marketed as an on-specification used oil fuel.....

F - Marketed as an off-specification used oil fuel.....

I - Marketed for an industrial process.....

B - Burned as an off-specification used oil fuel.....

D - Disposed of

 Landfilled.....

 Treated at a wastewater treatment unit.....

 Incinerated.....

	In State	Out of State
	2969105	
	150177	
	3119282	
	110986	

3. Total amount (in gallons) of used oil managed.....

4. End of year, on hand estimate (Difference between Lines 1D and Line 3).....

SECTION C USED OIL FILTERS (OPTIONAL) (USE TABLE BELOW FOR CONVERSIONS)

CHECK COLUMN IF OUT OF STATE ↓

1. Number of filters on hand from previous year.....	0	
2. Number of used oil filters collected.....	358872	
3. Total number of used oil filters to manage (1 plus 2).....	358872	
4. Disposition of used oil filters collected:	358872	
a. Transferred to another registered facility.....		
b. Burned for energy recovery at a Waste-To-Energy facility.....		
c. Transferred directly to a metal foundry for recycling.....		
d. TOTAL.....	358872	
5. End of year, on hand estimate (Difference between Lines 3 and Line 4d).....	0	
6. Gallons of used oil collected as a result of filter processing.....		
7. Gallons of used oil transferred to a used oil handler (transporter or processor).....		
8. Volume of oily waste collected and managed as a result of filter processing.....		
9. Description of oily waste management..... <u>WTE</u>		

DIRECTIONS FOR SECTION C

Conversion Table

One 55-gallon drum of crushed used oil filters = approximately 400 used oil filters
One 55 gallon drum of uncrushed used oil filters = approximately 250 used oil filters
One ton of drained used oil filters = approximately 2,350 used oil filters

1. Enter the number of Used Oil Filters on hand, from previous year's inventory.
2. Enter the number of Used Oil Filters collected.
3. Enter the sum of Line 1 + Line 2.
4. Enter the number of filters managed by your facility in blocks 4a-c. Enter the sum of 4a-c in block 4d .
5. Enter the number of filters on hand at your site as of December 31, last year.
6. Fill in the number of gallons of used oil collected by your filter operation.
7. Enter the number of gallons transferred to a used oil transporter or processor.
8. List the volume (gallons or cubic yards) of the oily wastes collected through your filter handling. Oily wastes are identified in Chapter 62-710.201(1) of the Florida Administrative Code and include bottom sludges, sorbents, wipes etc.
9. Describe how oily wastes were managed (sent to a WTE, hazardous waste facility, landfilled after appropriate testing, etc.).

Any questions concerning this form may be referred to the Used Oil Coordinator, MS 4560, Department of Environmental Protection 2600 Blair Stone Road, Tallahassee, FL 32399-2400, Phone (850) 245-8754, email: sebrena.bolton@dep.state.fl.us, OR Phone (850) 245-8755, email: aprilia.graves@dep.state.fl.us

Cliff Berry Inc

Used Oil Analysis Plan

General:

- A:** This Analysis Plan is applicable to all used oil processing operations at Cliff Berry Inc (CBI) facilities. The purpose of this plan is to detail those procedures which CBI employees must follow when complying with the used oil analysis requirements contained in 40 CFR 279.53.
- B:** A copy of this plan must be retained at each facility processing used oil. Each facility manager is responsible to ensure this plan is adhered to. If any errors, omissions or modifications to this plan are identified, they should be reported to the Director of Petroleum Services for review and update to this plan.

Procedures:

- A:** Drivers of used oil collection trucks will adhere to the following procedures when collecting used oil for delivery to a CBI facility.

Prior to collecting used oil, the driver will utilize a TIFF, Halogen Leak Detector to determine if the used oil contains elevated levels of halogens. If the leak detector indicates an elevated level of halogens, the driver will perform a field test using a DEXSIL Kit (CHLOR-D-TECT) Q-4000 to verify if the level is > than or < than 1000 parts per million (PPM). The DEXSIL kit conforms to EPA SW-846 Method 9077. A record of the halogen test result must be recorded on the manifest and job ticket.

Any time a DEXSIL Kit is used on site, a representative sample of the used oil must be taken. If it is determined that a client's oil has an elevated halogen level (>1000 PPM), then the used oil must not be loaded onto the truck. The sample must be retained by the driver and returned to his manager at CBI so a rebuttable presumption may be performed on the sample.

If, after re-testing, it is determined that the source of the halogens is from an inorganic source (chlorides, salt water), the oil may be removed for disposal as a non-hazardous liquid. If it is determined that the used oil has been mixed with a halogenated hazardous waste as defined in 40 CFR Part 261, the owner or operator must be immediately contacted and advised of the situation. CBI will then manage the used oil as a hazardous waste and arrange for proper disposal.

- B:** Upon arrival at a CBI facility, each used oil truck will have a composite sample of its load taken prior to off-loading. The sampling procedures to be followed must be consistent with the sampling of petroleum products guidelines (based upon API/MPMS chapter 8.1) attached as Appendix A. All samples of used oil (in-bound & out-bound) are to be retained at each CBI facility for a period of 90-days.

Use a DEXSIL Kit (CHLOR-D-TECT) Q-4000 to determine the amount (PPM) of halogens in the oil sample. Follow the directions on the kit for the preparation & analysis of the sample. A copy of the DEXSIL Kit (CHLOR-D-TECT) Q-4000 directions is attached as Appendix B.

If the used oil contains greater than 1000 PPM halogens, a rebuttable presumption may be performed. See attached Appendix C for rebuttable presumption flowchart.

- C:** On-Specification used oil that is to be burned for energy recovery must be sampled and sent to a certified laboratory to determine if it meets the fuel specifications of 40 CFR Part 279.11 prior to processing and/or re-refining.

Representative sampling will be done on batch loads of up to 75,000 gallons. Sampling will be conducted in accordance with the sampling procedures detailed in Appendix A.

The analysis of the used oil will be consistent with the appropriate analytical procedures used to determine whether a sample contains a given toxic constituent in accordance with EPA Publication SW-846, "Testing Methods for evaluating Solid Waste, Physical / Chemical Methods"

All on-specification used oil fuel must meet the following specifications:

Constituent / Property	Allowable Level
Arsenic	5 PPM Max
Cadmium	2 PPM Max
Chromium	10 PPM Max
Lead	100 PPM Max
Flash Point	100° F Minimum
Total Halogens	1000 PPM Max

Records of analysis conducted or information used to comply with the tracking requirements of 40 CFR Part 279 must be maintained for at least three years.

When tests are done to verify percent water and flash-point in the oil, they are to be conducted in accordance with the test procedures detailed in Appendix D and Appendix E respectively.



Print *printed July 22, 2006*

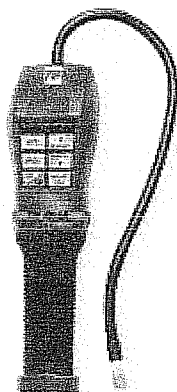

DETECTOR, LEAK

Detector, Leak Microprocessor Controlled, Sensitivity <0.1 Ounces Per Year, Six Tricolor LEDs for Visual Leak Indication, Seven Sensitivity Levels, One Touch Reset, Mute Button, Includes 2 C Batteries, Carrying Case, And Instructions

Grainger Item #	3BY19
Price (ea.)	\$290.00
Brand	TIF
Mfr. Model #	TIFXP-1A
Ship Qty.	1
Sell Qty. (Will-Call)	1
Ship Weight (lbs.)	3.0
Usually Ships	Today
Catalog Page No.	3881

Price shown may not reflect your price. Log in or register.

Additional Info

Leak Detectors

Microprocessor Controlled

Quickly and accurately detects all halogenated refrigerants, including R-12, R-11, R-500, R-503, R-22, R-123, R-124, R-502, R-125, R-134A, R-404A, R-410A, AZ-50, HP62, and MP36, plus unknown compounds.

Advanced digital signal processing monitors sensing tip up to 2000 times per second.

Has 7 sensitivity levels. Ergonomic design with a rubber cushion grip handle. Includes 2 C batteries and instructions. Meets SAE J1627. No. 3BY18 has 6 (single color) visual leak indication. No. 3BY19 has 18 (tri-color) visual leak indication. Nos. 3BY18 and 3BY19 have one touch reset. No. 3BY19 has a mute button.

Tech Specs

Sensitivity per Year: Less Than 0.1
Design: Ergonomic with a Rubber Cushion Grip Handle
Features: 7 Sensitivity Levels, Advanced Digital Signal Processing Monitors Sensing Tip Up to 2000 Times per Second
Function: Quickly and Accurately Detects all Halogenated Refrigerants
Includes: 2C Batteries, Carrying Case, and Instructions

Notes & Restrictions

Optional Accessories

Replacement Tips, Pk 3



Item #: 4YT91
 Brand: TIF
 Usually Ships: Today
 Price (ea): \$24.95

Battery, 1.5 V, C, Pk 12



Item #: 4WT08
 Brand: RAYOVAC

Appendix A

Sampling Petroleum Products (based on API/MPMS Chapter 8.1)

1. SAMPLING EQUIPMENT

Will Need:

Clean Bottles/Cans and caps
Sample cord
Weights or sampling cage
Wiping rags
Sample tags
Seals
DOT-approved box for transporting samples

2. SAMPLE CONTAINERS

Only new, clean bottles, jars, and caps should be used to draw and retain samples.

For most petroleum products, a 1-quart (1-liter) clear glass or linear polyethylene bottle with an approximate $\frac{3}{4}$ " opening is satisfactory. Screw caps with a polyethylene liner/seal should be used.

It is not possible to see inside metal cans to determine their cleanliness level. Therefore, it is good practice to rinse all cans with the product before placing samples in them.

3. GENERAL INSTRUCTIONS

Keep in mind that the purpose of taking samples is to obtain a portion of the contents of a tank which represents the entire tank from which the portion was taken. Precautions must be taken not to contaminate any sample with water, dust or other materials. Some conditions and some products require extraordinary sampling procedures.

Fill in sample tags with all applicable information. Write legibly and complete the hazardous code on the reverse side of every tag. Every sample must have a completed tag securely applied.

Carry sample containers to the job with caps in place to avoid contaminating the inside of the container.

Use clean sampling lines or lines which have only been used on similar, uncontaminated liquids

Keep sampling equipment clean; do not drag sample cord on the ground or the vessel's deck; do not use water-wet equipment

Tanks sampled should be gauged and gauges recorded. Gauges may be recorded from the automatic gauging system.

Use a sampling technique which is appropriate for the material being sampled.

If spot-samples must be taken (U-M-L, for example) start sampling with the uppermost sample and work your way toward the lowest sample. If both U-M-L and average samples are to be taken from the same tank, take average samples last.

Cap all sample containers securely.

To conform with DOT requirements, complete a shipping document before leaving any sampling site. This document must be carried with you on or near the front seat of your vehicle.

4. AVERAGE SAMPLING METHODS

ALL-LEVELS SAMPLING METHOD

This method is intended to take an average sample of the liquid beginning at the bottom of the tank and moving toward the top of the contents. This method is used when the depth or density of the liquid are such that the bottle would fill too quickly using the Running Sample Method.

A 1-quart stoppered bottle with an opening of approximately $\frac{3}{4}$ " is lowered to the point where sampling should start in the liquid. The sample cord is pulled sharply to remove the cork and the bottle is raised at a constant rate so that it is about 80% full when taken from the liquid.

If the bottle is more than 80% full, the sampling procedure must be repeated.

RUNNING SAMPLE METHOD

This method is intended to take an average sample of the liquid beginning at the top of the liquid, going to the lowest desired stopping point and returning to the top. This method is used when sampling dense or shallow liquids which would not permit the bottle to fill sufficiently with the ALL-LEVELS METHOD.

A 1-quart open bottle with an opening of approximately $\frac{3}{4}$ " is lowered to the desired point in the liquid and immediately raised, at a constant rate so that it is about 80% full when taken from the liquid.

If the bottle is more than 80% full, the sampling procedure must be repeated.

RESTRICTED-OPENING SAMPLE METHOD

This method is identical to the RUNNING-SAMPLE METHOD, except the opening of the sample bottle is made smaller by placing a cap on the bottle with a 3/8" hole, or using a split cork to reduce the bottle opening. This method is used when the sampling bottle would fill too quickly with the ALL-LEVELS SAMPLING METHOD.

LOADING-ZONE SAMPLING METHOD

This method is a unique combination of the RUNNING-SAMPLE METHOD and the SPOT-SAMPLING METHOD. An average sample is taken, but only from that portion of the tank which is expected to be loaded onto the vessel. For example, if only 1/3 of the tank contents were to be loaded onto a vessel, the stoppered bottle would be lowered to the 1/3 liquid innage level, the cord pulled to remove the stopper, then a running sample is taken in the lower 1/3 of the tank. Like the spot-sampling method, the sample bottle is allowed to fill completely in the loading zone.

5. SPOT-SAMPLING METHODS

A spot sample is any sample taken from one vertical level in a tank. Upper, Middle, Lower, Bottom and Top samples are examples of spot samples. A sample taken at, say, the 4'0" innage level in a tank would be a spot sample.

A stoppered bottle (size as above) is lowered to the desired sampling level. The sample cord is pulled sharply to remove the cork and the bottle is allowed to remain at that level until it is full. When the sample is retrieved from the liquid, pour off about 20% to allow expansion space for the liquid in the bottle.

When taking spot samples, start with the topmost sample first and work your way down into the liquid. This will minimize mixing of the material from one level with other levels.

Upper Samples are spot samples taken from the middle of the upper third of the liquid contents of the tank, not including any free water.

Lower Samples are spot samples taken from the middle of the lower third of the liquid contents of a tank, not including any free water.

Middle Samples are spot samples taken from the middle of the liquid contents of the tank, not including any free water.

Top Samples are spot samples taken from 6" below the surface of the liquid.

Bottom Samples are spot samples taken from the lowest level in the liquid above any free water.

6. SAMPLE HANDLING & TRANSPORTATION

Securely attach a completed sample tag to every sample, shore or vessel tank.

Submit a tank gauging report with samples if lab must composite.

Before transporting samples, the law requires that you do the following:

- **Complete a shipping document and place this document on or near the front seat of the vehicle you will use to transport the samples.**
- **Double-check samples to be certain they are capped securely and do not leak when inverted.**
- **Place the samples right-side-up into the DOT-approved sample box. If the box is not tightly packed, place cushioning between bottles so they will not collide and break in transit. Oil dry serves this purpose well, and is reusable. Clean wiping rags may also be used.**
- **Do not put reactive samples together in the same transportation chest or box.**
- **Drive with special care while you are carrying samples.**

APPENDIX B

INSTRUCTIONS FOR
CLOR-D-TECT[®] Q

Used Oil Titration Kit

Quantitative test kit for chlorine contamination in used oil.

EACH KIT CONTAINS:

1. A plastic test tube with white dispensing cap containing a colorless ampule (bottom) and a yellow-dotted gray ampule (top) - Tube #1.
2. A plastic test tube with a clear cap each containing 7 ml of a buffer solution and a red-green ampule - Tube #2.
3. A polypropylene sampling syringe and a tissue wipe.
4. A plastic filtration funnel.
5. A plastic titration burette attached to a plastic screw cap.
6. A white, plastic syringe plunger rod.
7. A glass ampule contained in a cardboard sleeve and plastic tube designated as "Disposal Ampule".

**READ CAUTION AND INFORMATION SECTIONS ON BACK BEFORE
PERFORMING TEST. WEAR RUBBER GLOVES AND SAFETY GLASSES.**

DIRECTIONS

1. PREPARATION Remove contents from box. Place the 2 plastic tubes into the holder at the front of the box.

2. SAMPLE INTRODUCTION Unscrew the white dispensing cap from Tube #1. Work the plunger on the empty sampling syringe a few times to ensure that it slides easily. Place the tip of the syringe into the oil sample to be tested and slowly pull back on the plunger until it reaches the stop and cannot be pulled further. Remove the syringe from the oil sample and wipe any excess sample from the outside of the syringe with enclosed tissue. Check the contents of the sampling syringe to ensure that the test sample is free of air bubbles (If not, discharge the oil sample and obtain a new sample). Place the tip of the syringe in Tube #1 and dispense the oil sample by depressing the plunger. Replace the white cap on the tube tightly.

DEXSIL[®]

CLOR-D-TECT IS A TRADEMARK OF THE DEXSIL CORPORATION AND
IS COVERED UNDER U.S. PATENT 5,013,667.

3. REACTION Break the bottom (colorless) ampule in the tube by compressing the sides of the tube. Mix thoroughly by shaking the tube vigorously for about 30 seconds. Break the top (gray) ampule in the tube and shake thoroughly for about 20 seconds. Allow the reaction to proceed for an additional 40 seconds (total of one minute), while shaking intermittently several times.

4. EXTRACTION Remove the caps from both tubes and pour the clear buffer solution from Tube #2 (clear cap) into Tube #1. Replace the white cap tightly on Tube #1 and shake vigorously for about 10 seconds. Vent the tube carefully by partially unscrewing the dispensing cap. Close securely and shake well for an additional 10 seconds. Vent again, tighten cap and stand tube upside down on its cap. Allow the phases to separate for a full two minutes.

5. ANALYSIS Place the plastic filtration funnel into Tube #2. Position Tube #1 over the funnel and open nozzle on the dispensing cap. Be sure to point the nozzle away from the operator while opening it, and check that the nozzle is open completely before dispensing the clear solution. Dispense 5 mls of the clear solution through the filter into Tube #2 (up to the line) by squeezing the sides of Tube #1. Do not allow any oil to pass through the filter into Tube #2. Close the nozzle on the dispensing cap on Tube #1 and remove the filter funnel from Tube #2.

6. Place the white plunger rod into the titration burette and press until it snaps into place. Tap the titrating burette gently while holding upright to ensure all air bubbles are on top next to the plunger. Break off (do not pull off) the tip on the titration burette. Place the burette into Tube #2 and tighten the cap. Break the colored ampule by squeezing the sides of the test tube and shake gently for 10 seconds. **Do NOT zero the plunger prior to analyzing the sample.**

7. Dispense titrant slowly by pushing down on the white plunger rod. Shake the tube continuously while adding titrant to mix the titrant with the solution. Continue adding titrant until the solution turns from yellow to light purple. An intermediate pink color may develop in the solution but should be disregarded. Continue titrating until a true light purple color is obtained. A dark purple color means the titration has been carried too far (see photo).

8. RESULTS Read the total chlorine concentration of the original oil sample directly on the titration burette at the black tip of the plunger rod. Record the total chlorine concentration immediately as the purple color will fade with time.

9. DISPOSAL Empty the titration burette into Tube #2 by completely depressing the plunger. Open the "Disposal Ampule" container and drop the ampule into Tube #2. Replace the cap on the test tube. Crush the ampule by squeezing the sides of the tube. Shake for 5 seconds. This reagent immobilizes the mercury so that the kit passes the EPA's TCLP test. See caution section below for additional information on disposal.

SUGGESTIONS FOR USING THE CLOR-D-TECT[®] Q TEST KIT

- ! The kit is designed for testing used oils and is not intended for use on water/oil mixtures that contain more than 20% water. For samples that contain more than 20% water, contact Dexsil about Hydroclor-Q[®] kit designed for testing samples for chlorinated organic compounds in water.
- ! The kit works well on all types of waste and used oils including crankcase, hydraulic, diesel, lubricating, fuel oils and kerosene. It is designed for use only on oils which are hydrocarbon-based. Some oils, such as cutting fluids which contain more than 3 or 4% sulfur may give false positive results. False negatives will not occur. For any questions regarding the applicability of the kit for your sample, contact Dexsil's technical service department.
- ! The kit should be examined upon opening to see that all of the components are present and that all the ampules (4) are in place and not leaking. The liquid in Tube #2 (clear cap) should be approximately 1/2 inch above the 5 ml line and the tube should not be leaking. The ampules are not intended to be completely full.
- ! Perform the test in a warm, dry area with adequate light. In cold weather, a truck cab is sufficient. If a warm area is not available, Step 3 should be performed while warming Tube #1 in palm of hand.
- ! Always crush the clear ampule in Tube #1 first. If this sequence has not been followed, stop the test immediately and start over using another complete kit. When an incorrect testing sequence is followed, a false negative may result which may allow a contaminated sample to pass without detection.
- ! In Step 4, when transferring the buffer solution from Tube #2 into Tube #1, tip Tube #2 to an angle of only 45° to prevent the ampule holder from sliding out.

CAUTION

- ! When crushing the glass ampules, press firmly in the center of the glass ampule **ONCE**. Never attempt to re-crush broken glass as it may come through the plastic and cut fingers.

- In case of accidental breakage or spillage onto skin or clothing, wash with large amounts of water. All the ampules are poisonous and should not be taken internally.
- Do not ship kits on passenger aircraft.
- The gray ampule in the white-capped test tube contains metallic sodium. Metallic sodium is a flammable solid and is water reactive.
- Wear rubber gloves and safety glasses while performing test.
- Dispose of used kits properly. The mercury in Tube #2 is made insoluble by the disposal ampule and used kits will pass the USEPA TCLP test for land disposal. More stringent state and local regulations may apply. Contact Dexsil if you have any specific questions concerning disposal procedure.
- Read the Material Safety Data Sheet before performing the test.
- Keep Out of Reach of Children.

MANUFACTURER'S WARRANTY

This kit is warranted to be free of defects in material and workmanship until the expiration date stamped on the box. Manufacturer's sole and exclusive liability under this warranty shall be limited to replacement of any kit that is proven to be defective. Manufacturer shall not be liable for any incidental or consequential damages.

Reliable test results are highly dependent upon the care with which the directions are followed and, consequently, cannot be guaranteed.

This kit is manufactured by **DEXSIL**[®] Corporation
One Hamden Park Drive, Hamden, Connecticut 06517
(203) 288-3509 FAX: (203) 248-6523
<http://www.dexsil.com>

• Printed on recycled paper

Revision 6, 5/06

Appendix C: Rebuttable Presumption Flowchart

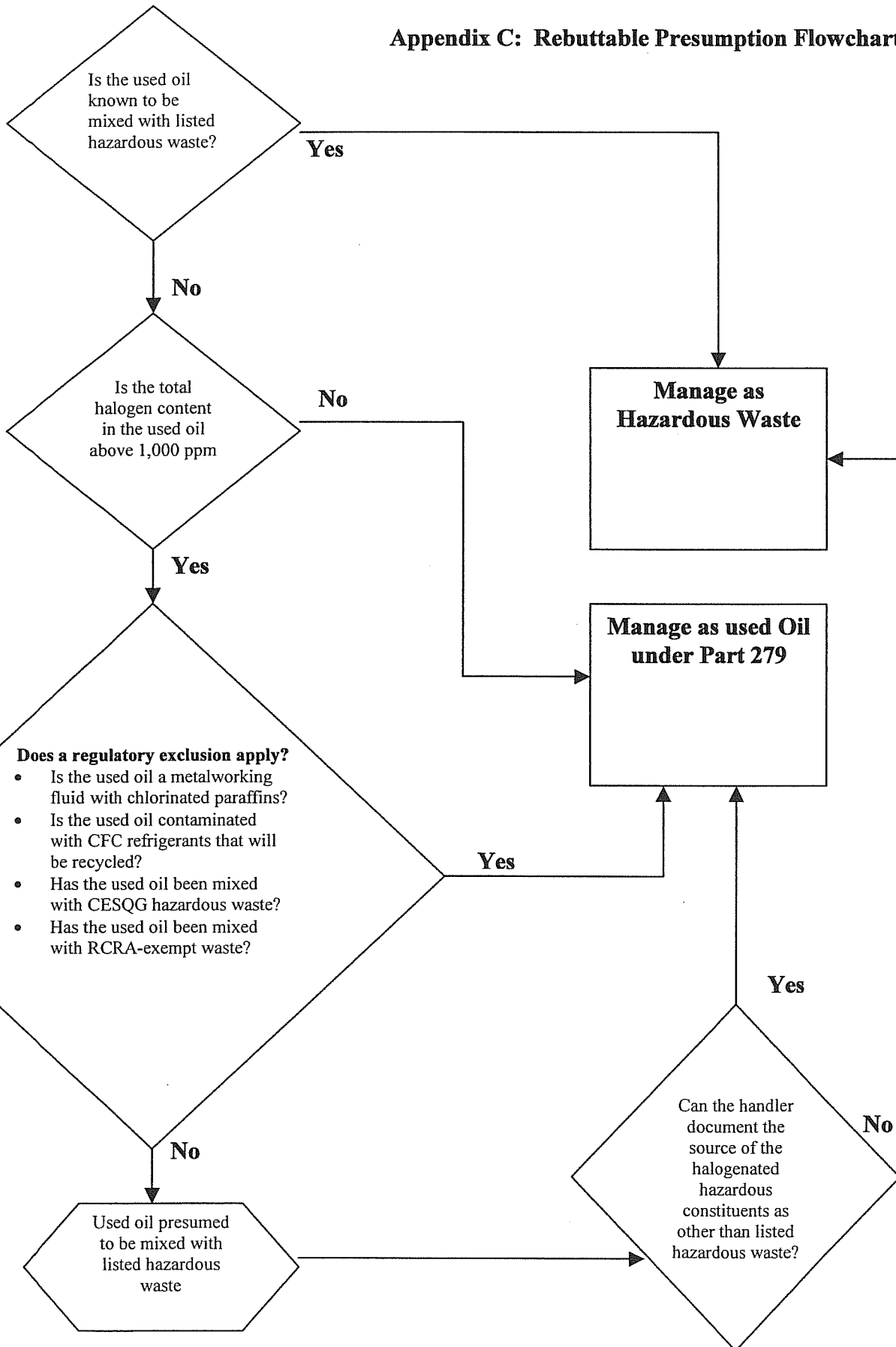



Designation: D 93 – 02a

An American National Standard



Designation: 34/99

Standard Test Methods for Flash Point by Pensky-Martens Closed Cup Tester¹

This standard is issued under the fixed designation D 93; the number immediately following the designation indicates the year of original adoption or, in the case of revision, the year of last revision. A number in parentheses indicates the year of last reapproval. A superscript epsilon (ϵ) indicates an editorial change since the last revision or reapproval.

This standard has been approved for use by agencies of the Department of Defense.

INTRODUCTION

This flash point test method is a dynamic test method and depends on definite rates of temperature increases to control the precision of the test method. The rate of heating may not in all cases give the precision quoted in the test method because of the low thermal conductivity of certain materials. To improve the prediction of flammability, Test Method D 3941, an equilibrium method, was developed in which the heating rate is slower. This allows the vapor above the test specimen and the test specimen to be at about the same temperature. If your specification requires Test Method D 93, do not substitute Test Method D 3941 or any other test method without obtaining comparative data and agreement from the specifier.

Flash point values are a function of the apparatus design, the condition of the apparatus used, and the operational procedure carried out. Flash point can therefore only be defined in terms of a standard test method, and no general valid correlation can be guaranteed between results obtained by different test methods, or with test apparatus different from that specified.

1. Scope *

1.1 These test methods cover the determination of the flash point of petroleum products in the temperature range from 40 to 360°C by a manual Pensky-Martens closed-cup apparatus or an automated Pensky-Martens closed-cup apparatus.

NOTE 1—Flash point determination as above 250°C can be performed, however, the precisions have not been determined above this temperature. For residual fuels, precisions have not been determined for flash points above 100°C.

1.2 Procedure A is applicable to distillate fuels (diesel, kerosine, heating oil, turbine fuels), new lubricating oils, and other homogeneous petroleum liquids not included in the scope of Procedure B.

1.3 Procedure B is applicable to residual fuel oils, cutback residua, used lubricating oils, mixtures of petroleum liquids with solids, petroleum liquids that tend to form a surface film under test conditions, or are petroleum liquids of such kinematic viscosity that they are not uniformly heated under the stirring and heating conditions of Procedure A.

1.4 These test methods is applicable for the detection of contamination of relatively nonvolatile or nonflammable materials with volatile or flammable materials.

1.5 The values stated in SI units shall be regarded as the standard. The values given in parentheses are provided for information only.

1.6 *This standard does not purport to address all of the safety concerns, if any, associated with its use. It is the responsibility of the user of this standard to establish appropriate safety and health practices and determine the applicability of regulatory limitations prior to use.* For specific hazards statements, see 6.4, 7.1, 9.3, 9.4, 11.1.2, 11.1.4, and 12.1.2.

2. Referenced Documents

2.1 ASTM Standards:

- D 56 Test Methods for Flash Point by Tag Closed Cup Tester²
- D 3941 Test Method for Flash Point by the Equilibrium Method with a Closed-Cup Apparatus³
- D 4057 Practice for Manual Sampling for Petroleum and Petroleum Products⁴

¹ These test methods are under the joint jurisdiction of ASTM Committee D02 on Petroleum Products and Lubricants and are the direct responsibility of Subcommittee D02.08 on Volatility. In the IP, these test methods are under the jurisdiction of the Standardization Committee.

Current edition approved Dec. 10, 2002. Published March 2003. Originally approved in 1921. Last previous edition approved in 2002 as D 93–02.

² *Annual Book of ASTM Standards*, Vol 05.01.

³ *Annual Book of ASTM Standards*, Vol 06.01.

⁴ *Annual Book of ASTM Standards*, Vol 05.02.

*A Summary of Changes section appears at the end of this standard.

Copyright © ASTM International, 100 Barr Harbor Drive, PO Box C700, West Conshohocken, PA 19428-2959, United States.

D 4177 Practice for Automatic Sampling of Petroleum and Petroleum Products⁴

E 1 Specification for ASTM Thermometers⁵

E 300 Practice for Sampling Industrial Chemicals⁶

E 502 Test Method for Selection and Use of ASTM Standards for the Determination of Flash Point of Chemicals by Closed Cup Methods⁷

2.2 ISO Standards⁸

Guide 34 Quality Systems Guidelines for the Production of Reference Materials

Guide 35 Certification of Reference Material—General and Statistical Principles

3. Terminology

3.1 Definitions:

3.1.1 *dynamic, adj—in petroleum products*—the condition where the vapor above the test specimen and the test specimen are not in temperature equilibrium at the time that the ignition source is applied.

3.1.1.1 *Discussion*—This is primarily caused by the heating of the test specimen at the constant prescribed rate with the vapor temperature lagging behind the test specimen temperature.

3.1.2 *equilibrium, n—in petroleum products*—the condition where the vapor above the test specimen and the test specimen are at the same temperature at the time the ignition source is applied.

3.1.2.1 *Discussion*—This condition may not be fully achieved in practice, since the temperature may not be uniform throughout the test specimen, and the test cover and shutter on the apparatus can be cooler.

3.1.3 *flash point, n—in petroleum products*, the lowest temperature corrected to a barometric pressure of 101.3 kPa (760 mm Hg), at which application of an ignition source causes the vapors of a specimen of the sample to ignite under specified conditions of test.

3.1.3.1 *Discussion*—The test specimen is deemed to have flashed when a flame appears and instantaneously propagates itself over the entire surface of the test specimen.

3.1.3.2 *Discussion*—When the ignition source is a test flame, the application of the test flame may cause a blue halo or an enlarged flame prior to the actual flash point. This is not a flash point and shall be ignored.

4. Summary of Test Method

4.1 A brass test cup of specified dimensions, filled to the inside mark with test specimen and fitted with a cover of specified dimensions, is heated and the specimen stirred at specified rates, by either of two defined procedures (A or B). An ignition source is directed into the test cup at regular intervals with simultaneous interruption of the stirring, until a flash is detected (see 3.1.3.1). The flash point is reported as defined in 3.1.3.

5. Significance and Use

5.1 The flash point temperature is one measure of the tendency of the test specimen to form a flammable mixture with air under controlled laboratory conditions. It is only one of a number of properties which must be considered in assessing the overall flammability hazard of a material.

5.2 Flash point is used in shipping and safety regulations to define *flammable* and *combustible* materials. One should consult the particular regulation involved for precise definitions of these classifications.

NOTE 2—The U.S. Department of Transportation (DOT)⁹ and U.S. Department of Labor (OSHA) have established that liquids with a flash point under 37.8°C (100°F) are flammable, as determined by these test methods, for those liquids which have a kinematic viscosity of 5.8 mm²/s (cSt) or more at 37.8°C or 9.5 mm²/s (cSt) or more at 25°C (77°F), or that contain suspended solids, or have a tendency to form a surface film while under test. Other classification flash points have been established by these departments for liquids using these test methods.

5.3 These test methods should be used to measure and describe the properties of materials, products, or assemblies in response to heat and an ignition source under controlled laboratory conditions and should not be used to describe or appraise the fire hazard or fire risk of materials, products, or assemblies under actual fire conditions. However, results of these test methods may be used as elements of a fire risk assessment which takes into account all of the factors which are pertinent to an assessment of the fire hazard of a particular end use.

5.4 These test methods provides the only closed cup flash point test procedures for temperatures up to 370°C (698°F).

6. Apparatus

6.1 *Pensky-Martens Closed Cup Apparatus (manual)*—This apparatus consists of the test cup, test cover and shutter, stirring device, heating source, ignition source device, air bath, and top plate described in detail in Annex A1. The assembled manual apparatus, test cup, test cup cover, and test cup assembly are illustrated in Figs. A1.1-A1.4, respectively. Dimensions are listed respectively.

6.2 *Pensky-Martens Closed Cup Apparatus (automated)*—This apparatus is an automated flash point instrument that is capable of performing the test in accordance with Section 11 (Procedure A) and Section 12 (Procedure B) of these test methods. The apparatus shall use the test cup, test cover and shutter, stirring device, heating source, and ignition source device described in detail in Annex A1.

6.3 *Temperature Measuring Device*—Is a thermometer having a range as shown as follows and conforming to the requirements prescribed in Specification E 1 or in Annex A3, or an electronic temperature measuring device, such as resistance thermometers or thermocouples. The device shall exhibit the same temperature response as the mercury thermometers.

⁵ Annual Book of ASTM Standards, Vol 14.03.

⁶ Annual Book of ASTM Standards, Vol 15.05.

⁷ Annual Book of ASTM Standards, Vol 14.02.

⁸ Available from American National Standards Institute (ANSI), 25 W. 43rd St., 4th Floor, New York, NY 10036.

⁹ For information on U.S. Department of Transportation regulations, see Codes of U.S. Regulations 49 CFR Chapter 1 and the U.S. Department of Labor, see 29 CFR Chapter XVII. Each of these items is revised annually and may be procured from the Superintendent of Documents, Government Printing Office, Washington, DC 20402.

Temperature Range	Thermometer Number	
	ASTM	IP
-5 to +110°C (20 to 230°F)	9C (9F)	15C
+10 to 200°C (50 to 392°F)	88C (88F)	101C
+90 to 370°C (200 to 700°F)	10C (10F)	16C

6.4 *Ignition Source*—Natural gas flame, bottled gas flame, and electric ignitors (hot wire) have been found acceptable for use as the ignition source. The gas flame device described in detail in Fig. A1.4 requires the use of the pilot flame described in A1.1.2.3. The electric ignitors shall be of the hot-wire type and shall position the heated section of the ignitor in the aperture of the test cover in the same manner as the gas flame device. (**Warning**—Gas pressure supplied to the apparatus should not be allowed to exceed 3 kPa (12 in.) of water pressure.)

7. Reagents and Materials

7.1 *Cleaning Solvents*—Use suitable solvent capable of cleaning out the specimen from the test cup and drying the test cup and cover. Some commonly used solvents are toluene and acetone. (**Warning**—Toluene, acetone, and many solvents are flammable and a health hazard. Dispose of solvents and waste material in accordance with local regulations.)

8. Sampling

8.1 Obtain a sample in accordance with instructions given in Practices D 4057, D 4177, or E 300.

8.2 At least 75 mL of sample is required for each test. Refer to Practice D 4057. When obtaining a sample of residual fuel oil, the sample container shall be from 85 to 95 % full. For other types of samples, the size of the container shall be chosen such that the container is not more than 85 % full or less than 50 % full prior to any sample aliquot being taken.

8.3 Successive test specimens can be taken from the same sample container. Repeat tests have been shown to be within the precisions of the method when the second specimen is taken with the sample container at least 50 % filled. The results of flash point determinations can be affected if the sample volume is less than 50 % of sample container capacity.

8.4 Erroneously high flash points may be obtained if precautions are not taken to avoid the loss of volatile material. Do not open containers unnecessarily, to prevent loss of volatile material or possible introduction of moisture, or both. Avoid storage of samples at temperatures in excess of 35°C or 95°F. Samples for storage shall be capped tightly with inner seals. Do not make a transfer unless the sample temperature is at least the equivalent of 18°C or 32°F below the expected flash point.

8.5 Do not store samples in gas-permeable containers, since volatile material may diffuse through the walls of the enclosure. Samples in leaky containers are suspect and not a source of valid results.

8.6 Samples of very viscous materials shall be heated in their containers, with lid/cap slightly loosened to avoid buildup of dangerous pressure, at the lowest temperature adequate to liquefy any solids, not exceeding 28°C or 50°F below the expected flash point, for 30 min. If the sample is then not completely liquefied, extend the heating period for additional 30 min periods as necessary. Then gently agitate the sample to provide mixing, such as orbiting the container horizontally,

before transferring to the specimen cup. No sample shall be heated and transferred unless its temperature is more than 18°C or 32°F below its expected flash point. When the sample has been heated above this temperature, allow the sample to cool until its temperature is at least 18°C or 32°F below the expected flash point before transferring.

NOTE 3—Volatile vapors can escape during heating when the sample container is not properly sealed.

NOTE 4—Some viscous samples may not completely liquefy even after prolonged periods of heating. Care should be exercised when increasing the heating temperature to avoid unnecessary loss of volatile vapors, or heating the sample too close to the flash point.

8.7 Samples containing dissolved or free water may be dehydrated with calcium chloride or by filtering through a qualitative filter paper or a loose plug of dry absorbent cotton. Warming the sample is permitted, but it shall not be heated for prolonged periods or greater than a temperature of 18°C 32°F below its expected flash point.

NOTE 5—If the sample is suspected of containing volatile contaminants, the treatment described in 8.6 and 8.7 should be omitted.

9. Preparation of Apparatus

9.1 Support the manual or automated apparatus on a level steady surface, such as a table.

9.2 Tests are to be performed in a draft-free room or compartment. Tests made in a laboratory hood or in any location where drafts occur are not reliable.

NOTE 6—A shield, of the approximate dimensions 460 mm (18 in.) square and 610 mm (24 in.) high, or other suitable dimensions, and having an open front is recommended to prevent drafts from disturbing the vapors above the test cup.

NOTE 7—With some samples whose vapors or products of pyrolysis are objectionable, it is permissible to place the apparatus along with a draft shield in a ventilation hood, the draft of which is adjustable so that vapors can be withdrawn without causing air currents over the test cup during the ignition source application period.

9.3 Prepare the manual apparatus or the automated apparatus for operation in accordance with the manufacturer's instructions for calibrating, checking, and operating the equipment. (**Warning**—Gas pressure should not be allowed to exceed 3 kPa (12 in.) of water pressure.)

9.4 Thoroughly clean and dry all parts of the test cup and its accessories before starting the test, to ensure the removal of any solvent which had been used to clean the apparatus. Use suitable solvent capable of removing all of the specimen from the test cup and drying the test cup and cover. Some commonly used solvents are toluene and acetone. (**Warning**—Toluene, acetone, and many solvents are flammable. Health hazard. Dispose of solvents and waste material in accordance with local regulations.)

10. Verification of Apparatus

10.1 Adjust the automated flash point detection system (when used) in accordance with the manufacturer's instructions.

10.2 Verify that the temperature measuring device is in accordance with 6.3.

10.3 Verify the performance of the manual apparatus or the automated apparatus at least once per year by determining the

flash point of a certified reference material (CRM) such as those listed in Annex A4, which is reasonably close to the expected temperature range of the samples to be tested. The material shall be tested according to Procedure A of these test methods and the observed flash point obtained in 11.1.8 or 11.2.2 shall be corrected for barometric pressure (see Section 13). The flash point obtained shall be within the limits stated in Table A4.1 for the identified CRM or within the limits calculated for an unlisted CRM (see Annex A4).

10.4 Once the performance of the apparatus has been verified, the flash point of secondary working standards (SWs) can be determined along with their control limits. These secondary materials can then be utilized for more frequent performance checks (see Annex A4).

10.5 When the flash point obtained is not within the limits stated in 10.3 or 10.4, check the condition and operation of the apparatus to ensure conformity with the details listed in Annex A1, especially with regard to tightness of the lid (A1.1.2.2), the action of the shutter, the position of the ignition source (A1.1.2.3), and the angle and position of the temperature measuring device (A1.1.2.4). After any adjustment, repeat the test in 10.3 using a fresh test specimen, with special attention to the procedural details prescribed in these test methods.

PROCEDURE A

11. Procedure

11.1 *Manual Apparatus:*

11.1.1 Ensure that the sample container is filled to the volume capacity requirement specified in 8.2. Fill the test cup with the test specimen to the filling mark inside of the test cup. The temperature of the test cup and test specimen shall be at least 18°C or 32°F below the expected flash point. If too much test specimen has been added to the test cup, remove the excess using a syringe or similar device for withdrawal of fluid. Place the test cover on the test cup and place the assembly into the apparatus. Be sure the locating or locking device is properly engaged. If the temperature measuring device is not already in place, insert the device into its holder.

11.1.2 Light the test flame, and adjust it to a diameter of 3.2 to 4.8 mm (0.126 to 0.189 in.), or switch on the electric igniter and adjust the intensity in accordance with the manufacturer's instructions. (**Warning**—Gas pressure should not be allowed to exceed 3 kPa (12 in.) of water pressure.) (**Warning**—Exercise care when using a gas test flame. If it should be extinguished it will not ignite the vapors in the test cup, and the gas for the test flame that then enters the vapor space can influence the result.) (**Warning**—The operator should exercise and take appropriate safety precautions during the initial application of the ignition source, since test specimens containing low-flash material can give an abnormally strong flash when the ignition source is first applied.) (**Warning**—The operator should exercise and take appropriate safety precautions during the performance of these test methods. The temperatures attained during these test methods, up to 370°C (698°F), are considered hazardous.)

11.1.3 Apply the heat at such a rate that the temperature, as indicated by the temperature measuring device, increases 5 to 6°C (9 to 11°F)/min.

11.1.4 Turn the stirring device at 90 to 120 rpm, stirring in a downward direction. (**Warning**—Meticulous attention to all details relating to the ignition source, size of test flame or intensity of the electric ignitor, rate of temperature increase, and rate of dipping the ignition source into the vapor of the test specimen is desirable for good results.)

11.1.5 *Application of Ignition Source:*

11.1.5.1 If the test specimen is expected to have a flash point of 110°C or 230°F or below, apply the ignition source when the temperature of the test specimen is $23 \pm 5^\circ\text{C}$ or $41 \pm 9^\circ\text{F}$ below the expected flash point and each time thereafter at a temperature reading that is a multiple of 1°C or 2°F. Discontinue the stirring of the test specimen and apply the ignition source by operating the mechanism on the test cover which controls the shutter so that the ignition source is lowered into the vapor space of the test cup in 0.5 s, left in its lowered position for 1 s, and quickly raised to its upward position.

11.1.5.2 If the test specimen is expected to have a flash point above 110°C or 230°F, apply the ignition source in the manner described in 11.1.5.1 at each temperature increase of 2°C or 5°F, beginning at a temperature of $23 \pm 5^\circ\text{C}$ or $41 \pm 9^\circ\text{F}$ below the expected flash point.

11.1.6 When testing materials to determine if volatile material contamination is present, it is not necessary to adhere to the temperature limits for initial ignition source application as stated in 11.1.5.

11.1.7 When testing materials where the expected flash point temperature is not known, bring the material to be tested and the tester to a temperature of $15 \pm 5^\circ\text{C}$ or $60 \pm 10^\circ\text{F}$. When the material is known to be very viscous at this temperature, heat the specimen to a starting temperature as described in 8.6. Apply the ignition source, in the manner described in 11.1.5.1, beginning at least 5°C or 10°F higher than the starting temperature.

Note 8—Flash Point results determined in an “unknown expected flash point mode” should be considered approximate. This value can be used as the expected flash point when a fresh specimen is tested in the standard mode of operation.

11.1.8 Record as the observed flash point the reading on the temperature measuring device at the time ignition source application causes a distinct flash in the interior of the test cup. The sample is deemed to have flashed when a large flame appears and instantaneously propagates itself over the entire surface of the test specimen. (**Warning**—For certain mixtures containing halogenated hydrocarbons, such as, methylene chloride or trichloroethylene, no distinct flash, as defined, is observed. Instead a significant enlargement of the test flame (not halo effect) and change in color of the test flame from blue to yellowish-orange occurs. Continued heating and testing of these samples above ambient temperature can result in significant burning of vapors outside the test cup, and can be a potential fire hazard. See Appendix X1 and Appendix X2 for more information.)

11.1.9 When the ignition source is a test flame, the application of the test flame may cause a blue halo or an enlarged flame prior to the actual flash point. This is not a flash and shall be ignored.

11.1.10 When a flash point is detected on the first application, the test shall be discontinued, the result discarded, and the test repeated with a fresh test specimen. The first application of the ignition source with the fresh test specimen shall be $23 \pm 5^\circ\text{C}$ or $41 \pm 9^\circ\text{F}$ below the temperature at which a flash point was detected on the first application.

11.1.11 When a flash point is detected at a temperature which is greater than 28°C or 50°F above the temperature of the first application of the ignition source, or when a flash point is detected at a temperature which is less than 18°C or 32°F above the temperature of the first application of the ignition source, the result shall be considered approximate, and the test repeated with a fresh test specimen. Adjust the expected flash point for this next test to the temperature of the approximate result. The first application of the ignition source with the fresh test specimen shall be $23 \pm 5^\circ\text{C}$ or $41 \pm 9^\circ\text{F}$ below the temperature at which the approximate result was found.

11.1.12 When the apparatus has cooled down to a safe handling temperature, less than 55°C (130°F), remove the test cover and the test cup and clean the apparatus as recommended by the manufacturer.

NOTE 9—Exercise care when cleaning and positioning the lid assembly so not to damage or dislocate the flash detection system or temperature measuring device. See the manufacturer's instructions for proper care and maintenance.

11.2 Automated Apparatus:

11.2.1 The automated apparatus shall be capable of performing the procedure as described in 11.1, including control of the heating rate, stirring of the test specimen, application of the ignition source, detection of the flash point, and recording the flash point.

11.2.2 Start the automated apparatus in accordance with the manufacturer's instructions. The apparatus shall follow the procedural details described in 11.1.3 through 11.1.8.

PROCEDURE B

12. Procedure

12.1 Manual Apparatus:

12.1.1 Ensure that the sample container is filled to the volume capacity requirement specified in 8.2. Fill the test cup with the test specimen to the filling mark inside of the test cup. The temperature of the test cup and test specimen shall be at least 18°C or 32°F below the expected flash point. If too much test specimen has been added to the test cup, remove the excess using a syringe or similar device for withdrawal of fluid. Place the test cover on the test cup and place the assembly into the apparatus. Be sure the locating or locking device is properly engaged. If the temperature measuring device is not already in place, insert the device into its holder.

12.1.2 Light the test flame and adjust it to a diameter of 3.2 to 4.8 mm (0.126 to 0.189 in.), or switch on the electric igniter and adjust the intensity in accordance with the manufacturer's instructions. (**Warning**—Gas pressure should not be allowed to exceed 3 kPa (12 in.) of water pressure.) (**Warning**—Exercise care when using a gas test flame. If it should be extinguished it will not ignite the vapors in the test cup and the gas for the test flame that then enters the vapor space can influence the result.) (**Warning**—The operator should exercise

and take appropriate safety precautions during the initial application of the ignition source, since test specimens containing low-flash material may give an abnormally strong flash when the ignition source is first applied.) (**Warning**—The operator should exercise and take appropriate safety precautions during the performance of these test methods. The temperatures attained during these test methods, up to 370°C (698°F), are considered hazardous.)

12.1.3 Turn the stirring device at 250 ± 10 rpm, stirring in a downward direction.

12.1.4 Apply the heat at such a rate that the temperature as indicated by the temperature measuring device increases 1 to 1.6°C (2 to 3°F)/min.

12.1.5 Proceed as prescribed in Section 11, with the exception of the preceding requirements for rates of stirring and heating.

12.2 Automated Apparatus:

12.2.1 The automated apparatus shall be capable of performing the procedure as described in 12.1, including control of the heating rate, stirring of the test specimen, application of the ignition source, detection of the flash point, and recording the flash point.

12.2.2 Start the automated apparatus in accordance with the manufacturer's instructions. The apparatus shall follow the procedural details in accordance with 12.1.3 through 12.1.5.

PRECISION, CALCULATION, AND REPORT FOR PROCEDURES A AND B

13. Calculation

13.1 Observe and record the ambient barometric pressure (see Note 10) at the time of the test. When the pressure differs from 101.3 kPa (760 mm Hg), correct the flash point as follows:

$$\text{Corrected flash point} = C + 0.25(101.3 - K) \quad (1)$$

$$\text{Corrected flash point} = F + 0.06(760 - P) \quad (2)$$

$$\text{Corrected flash point} = C + 0.033(760 - P) \quad (3)$$

where:

C = observed flash point, $^\circ\text{C}$,

F = observed flash point, $^\circ\text{F}$,

P = ambient barometric pressure, mm Hg, and

K = ambient barometric pressure, kPa.

NOTE 10—The barometric pressure used in this calculation is the ambient pressure for the laboratory at the time of the test. Many aneroid barometers, such as those used at weather stations and airports, are precorrected to give sea level readings and would not give the correct reading for this test.

13.2 After correction for barometric pressure, round the temperature to the nearest 0.5°C (1°F) and record.

14. Report

14.1 Report the corrected flash point as the ASTM D 93–IP 34, Procedure A or Procedure B Pensky-Martens Closed Cup Flash Point of the test specimen.

15. Precision and Bias (Procedure A)

15.1 *Precision*—The precision of this procedure as determined by the statistical examination of the interlaboratory test results, is as follows:

15.1.1 *Repeatability*—The difference between successive results, obtained by the same operator with the same apparatus under constant operating conditions on identical test material, would in the long run, in the normal and correct operation of the test method, exceed the following values in 1 case in 20.

$$r = AX, \quad (4)$$

$$A = 0.029,$$

X = mean result in °C, and

r = repeatability.

15.1.2 *Reproducibility*—The difference between two single and independent results, obtained by different operators working in different laboratories on identical material, would in the long run, in the normal and correct operation of the test method, exceed the following values only in 1 case in 20.

$$R = BX, \quad (5)$$

$$B = 0.071,$$

X = mean result in °C, and

R = reproducibility.

15.1.3 *Bias*—Since there is no accepted reference material suitable for determining the bias for the procedure in these test methods, bias has not been determined.

15.1.4 *Relative Bias*—Statistical evaluation of the data did not detect any significant difference between the reproducibility variances of manual and automated Pensky-Martens flash point results for the samples studied. Evaluation of the data did not detect any significant difference between averages of manual and automated Pensky-Martens flash point for the samples studied with the exception of cycle oil and fuel oil which showed some bias. In any case of dispute, the manual procedure shall be considered the referee test.

NOTE 11—The precision statements were derived on clear liquids only. Refer to the research report¹⁰ for information regarding relative bias and types of samples. Additional studies are in progress concerning relative bias.

15.1.5 The precision data were developed from a combined 1991 ASTM cooperative test program¹⁰ using 5 samples of fuel and lubricating oils (Twelve laboratories participated with the

¹⁰ Supporting data (the results of the 1991 interlaboratory cooperative test program) have been filed at ASTM International Headquarters and may be obtained by requesting Research Report RR: S15-1008.

manual apparatus and 21 laboratories participated with the automated equipment) and a 1994 IP cooperative test program using 12 fuel samples and 4 pure chemicals. (Twenty-six laboratories participated with manual and automated equipment. The apparatus used either a gas test flame or an electric resistance (hot wire) device for the ignition source. Information on the type of samples and their average flash point are in the research report.¹⁰

16. Precision and Bias (Procedure B)

16.1 *Precision*—The precision of this procedure as determined by the statistical examination of the interlaboratory test results, is as follows:

16.1.1 *Repeatability*—The difference between successive results obtained by the same operator with the same apparatus under constant operating conditions on identical test materials would, in the long run, in the normal and correct operation of the test method, exceed the following value in 1 case in 20:

$$\begin{array}{l} \text{Residual fuel oil } 2^{\circ}\text{C } (5^{\circ}\text{F}) \\ \text{Other types } 5^{\circ}\text{C } (9^{\circ}\text{F}) \end{array} \quad (6)$$

16.1.2 *Reproducibility*—The difference between two single and independent results obtained by different operators working in different laboratories on identical material would, in the long run, exceed the following value only in 1 case in 20.

$$\begin{array}{l} \text{Residual fuel oil } 6^{\circ}\text{C } (12^{\circ}\text{F}) \\ \text{Other types } 10^{\circ}\text{C } (18^{\circ}\text{F}) \end{array} \quad (7)$$

16.1.3 *Bias*—Since there is no accepted reference material suitable for determining the bias for the procedure in these test methods, bias has not been determined.

16.1.4 The precision data for residual fuel oils were developed in a 1996 cooperative test program conducted by the IP using 12 samples of residual fuel and 40 laboratories worldwide using both the manual and automated apparatus. Information on the type of samples and their average flash point are in the research report.

16.1.5 The precision data for other sample types in Procedure B is not known to have been developed in accordance with RR:D02-1007.¹¹

NOTE 12—Procedure B was not tested in the 1991 interlaboratory program.

17. Keywords

17.1 automated flash point; automated Pensky-Martens closed cup; flammability; flash point; Pensky-Martens closed cup

¹¹ Supporting data have been filed at ASTM International Headquarters and may be obtained by requesting Research Report RR: D02-1007.

ANNEXES

(Mandatory Information)

A1. APPARATUS SPECIFICATIONS

A1.1 A typical assembly of the apparatus, gas heated, is shown in Fig. A1.1. The apparatus shall consist of a test cup, cover, and stove conforming to the following requirements:

A1.1.1 *Cup*—The cup shall be of brass, or other nonrusting metal of equivalent heat conductivity, and shall conform to the dimensional requirements in Fig. A1.2. The flange shall be

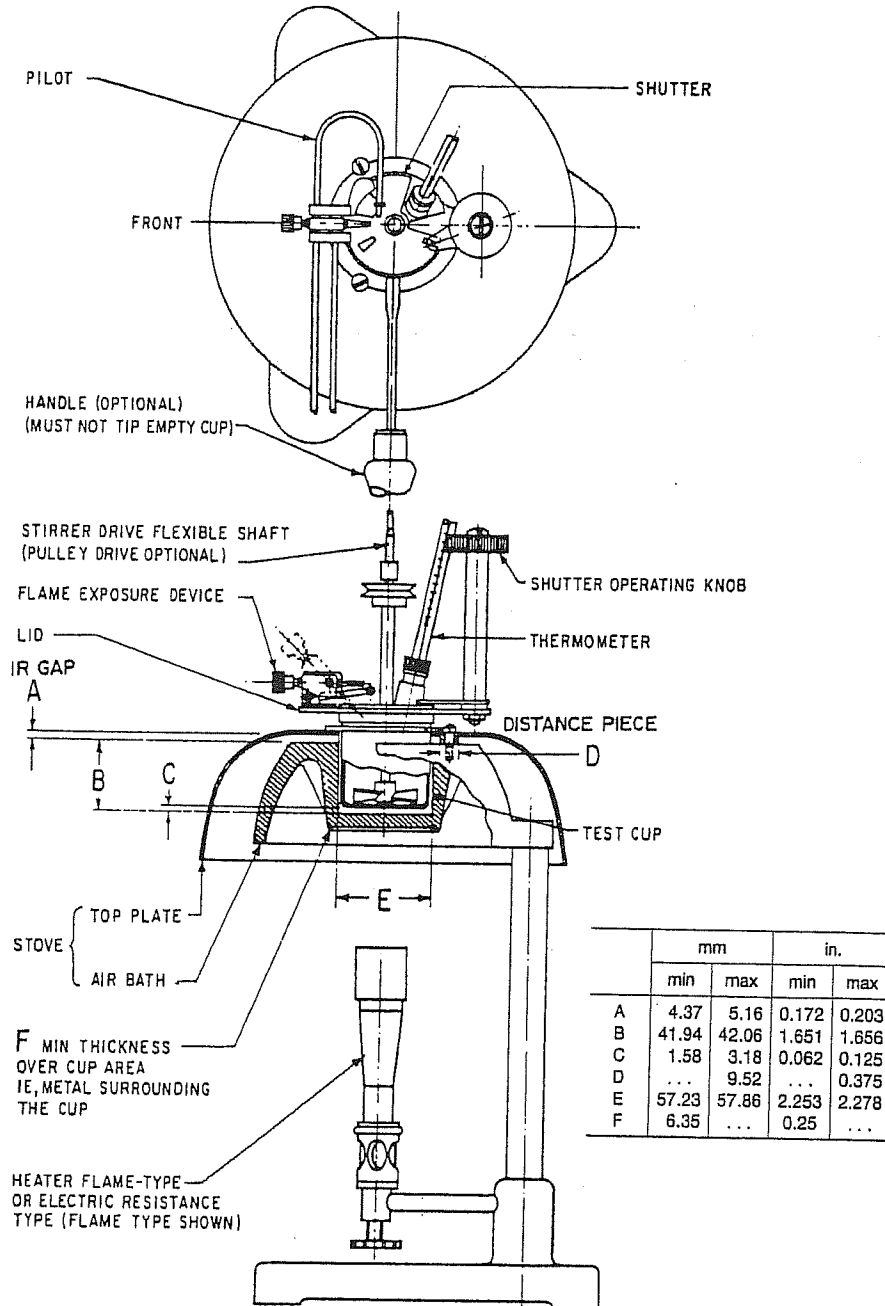

NOTE 1—Lid assembly can be positioned either right or left-handed.

FIG. A1.1 Pensky-Martens Closed Flash Tester

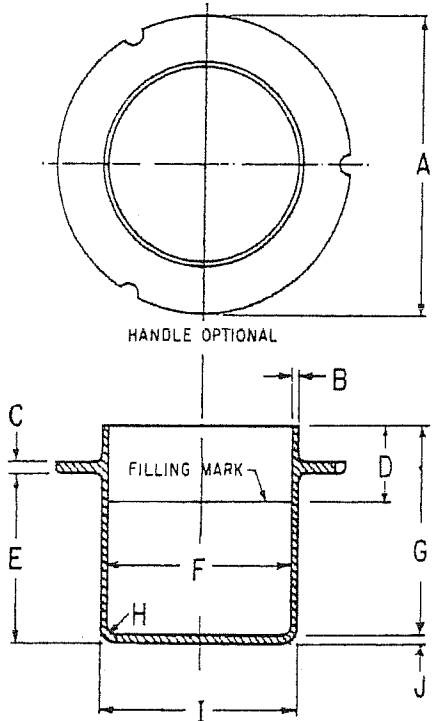

	mm		(in.)	
	min	max	(min)	(max)
A	79.0	79.8	(3.11)	(3.14)
B	1.0	...	(0.04)	(...)
C	2.8	3.6	(0.11)	(0.14)
D	21.72	21.84	(0.855)	(0.860)
E	45.47	45.72	(1.790)	(1.800)
F	50.72	50.85	(1.997)	(2.002)
G	55.75	56.00	(2.195)	(2.205)
H	3.8	4.0	(0.15)	(0.16)
I	53.90	54.02	(2.122)	(2.127)
J	2.29	2.54	(0.090)	(0.100)

FIG. A1.2 Test Cup

equipped with devices for locating the position of the cup in the stove. A handle attached to the flange of the cup is a desirable accessory. The handle shall not be so heavy as to tip over the empty cup.

A1.1.2 Cover:

A1.1.2.1 *Cover Proper*—The cover shown in Fig. A1.3 shall be of brass (A1.1.1) and shall have a rim projecting downward almost to the flange of the cup. The rim shall fit the outside of the cup with a clearance not exceeding 0.36 mm (0.014 in.) on the diameter. There shall be a locating or locking device, or both, engaging with a corresponding device on the cup. The four openings in the cover, A, B, C, and D, are shown in Fig. A1.3. The upper edge of the cup shall be in close contact with the inner face of the cover throughout its circumference.

A1.1.2.2 *Shutter*—The cover shall be equipped with a brass shutter (Fig. A1.1 and Fig. A1.4), approximately 2.4 mm (3/32 in.) thick, operating on the plane of the upper surface of the cover. The shutter shall be so shaped and mounted that it rotates on the axis of the horizontal center of the cover between two stops, so placed, that when in one extreme position, the

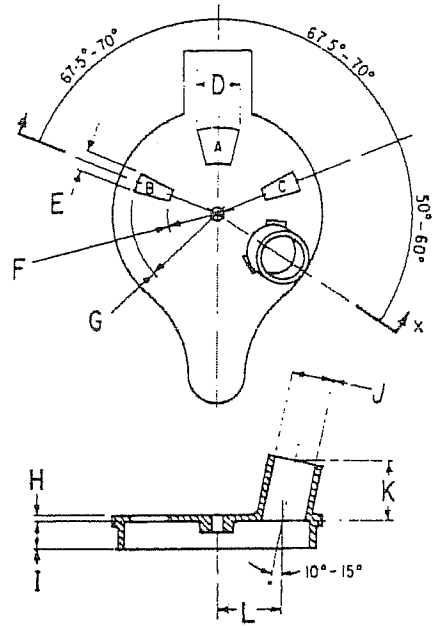

	mm		(in.)	
	min	max	(min)	(max)
D	12.7	13.5	(0.50)	(0.53)
E	4.8	5.6	(0.19)	(0.22)
F	13.5	14.3	(0.53)	(0.56)
G	23.8	24.6	(0.94)	(0.97)
H	1.2	2.0	(0.05)	(0.08)
I	7.9	...	(0.31)	(...)
J	12.00	12.32	(0.472)	(0.485)
K	16.38	17.00	(0.645)	(0.669)
L	18.65	19.45	(0.734)	(0.766)

FIG. A1.3 Cover Proper

openings A, B, and C in the cover are completely closed, and when in the other extreme position, these openings are completely opened. The mechanism operating the shutter should be of the spring type and constructed so that when at rest the shutter shall exactly close the three openings. When operated to the other extreme, the three cover openings shall be exactly open and the tip of the exposure tube shall be fully depressed.

A1.1.2.3 *Flame-Ignition Device*—The flame-ignition device (Fig. A1.4) shall have a tip with an opening 0.69 to 0.79 mm (0.027 to 0.031 in.) in diameter. This tip shall be made preferably of stainless steel, although it may be fabricated of other suitable metals. The flame-exposure device shall be equipped with an operating mechanism which, when the shutter is in the open position, depresses the tip so that the center of the orifice is between the planes of the under and upper surfaces of the cover proper at a point on a radius passing through the center of the larger opening A (Fig. A1.3). An electric ignitor is also suitable. The electric ignitors shall be of the electric resistance (hot-wire) type and shall position the heated section of the ignitor in the aperture of the test cover in the same manner as the gas flame device.

A1.1.2.4 *Pilot Flame*—A pilot flame shall be provided for automatic relighting of the exposure flame. A bead 4 mm (3/16 in.) in diameter can be mounted on the cover so that the

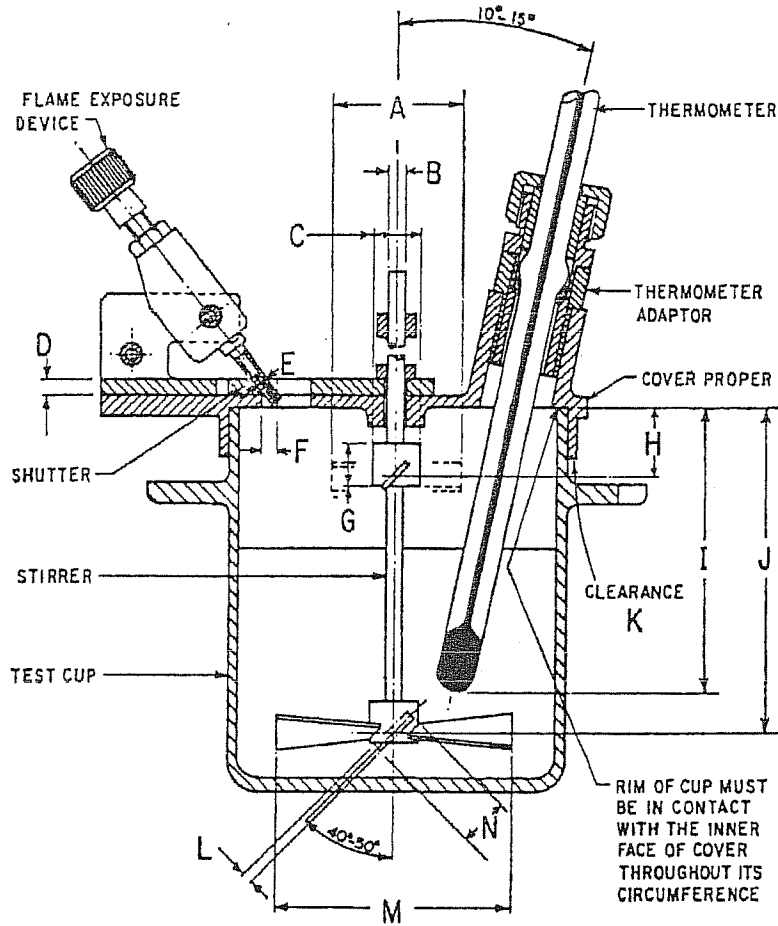

	mm		(in.)	
	min	max	(min)	(max)
A	18.3	19.8	(0.72)	(0.78)
B	2.38	3.18	(0.094)	(0.125)
C	7.6	8.4	(0.30)	(0.33)
D	2.0	2.8	(0.08)	(0.11)
E	0.69	0.79	(0.027)	(0.031)
F	2.0	2.8	(0.08)	(0.11)
G	6.4	10.4	(0.25)	(0.41)
H	9.6	11.2	(0.38)	(0.44)
J ^A	43.0	46.0	(1.69)	(1.81)
J	50.0	51.6	(1.97)	(2.03)
K	...	0.36	(...)	(0.014)
L	1.22	2.06	(0.048)	(0.08)
M	31.8	44.4	(1.25)	(1.75)
N	7.6	8.4	(0.30)	(0.33)

^A Includes tolerance for length of thermometer given in Specification E 1.

FIG. A1.4 Test Cup and Cover Assembly

size of the test flame can be regulated by comparison. The tip of the pilot flame shall have an opening the same size as the tip of the flame exposure device (0.69 to 0.79 mm (0.027 to 0.031 in.) in diameter).

A1.1.2.5 *Stirring Device*—The cover shall be equipped with a stirring device (Fig. A1.4) mounted in the center of the cover and carrying two 2-bladed metal propellers. In Fig. A1.4 lower propeller is designated by the letters L, M, and N. This

propeller shall measure approximately 38 mm from tip to tip, with each of its two blades 8 mm in width with a pitch of 45°. The upper propeller is designated by the letters A, C, and G. This propeller measures approximately 19 mm, tip to tip, each of its two blades is also 8 mm in width with a pitch of 45°. Both propellers are located on the stirrer shaft in such a manner that, when viewed from the bottom of the stirrer, the blades of one propeller are at 0 and 180° while the blades of the other

propeller are at 90 and 270°. A stirrer shaft may be coupled to the motor by a flexible shaft or a suitable arrangement of pulleys.

A1.1.2.6 *Stove*—Heat shall be supplied to the cup by means of a properly designed stove which is equivalent to an air bath. The stove shall consist of an air bath and a top plate on which the flange of the cup rests.

A1.1.2.7 *Air Bath*—The air bath shall have a cylindrical interior and shall conform to the dimensional requirements in Fig. A1.1. The air bath may be either a flame or electrically heated metal casting (A1.1.2.8), or an electric-resistance element (A1.1.2.9). In either case, the air bath must be suitable for use at the temperatures to which it will be subjected without deformation.

A1.1.2.8 *Heater, Flame or Electric*—If the heating element is a flame or an electric heater, it shall be so designed and used that the temperatures of the bottom and the walls are approximately the same. In order that the air bath internal surfaces should be at a uniform temperature, it should not be less than

6.4 mm (¼ in.) in thickness unless the heating element is designed to give equal heat flux densities over all the wall and bottom surfaces.

A1.1.2.9 *Heater, Electric Resistance*—If the heater is of the electric resistance type, it shall be constructed so that all parts of the interior surface are heated uniformly. The wall and bottom of the air bath shall not be less than 6.4 mm (¼ in.) in thickness unless the resistance heating elements are distributed over at least 80 % of the wall and all the bottom of the air bath. A heater having such a distribution of the heating elements positioned at least 4.0 mm (5/32 in.) away from the internal surface of the heating unit can be used in conjunction with a minimum thickness of 1.58 mm (1/16 in.) for the wall and bottom of the air bath.

A1.1.2.10 *Top Plate*—The top plate shall be of metal, and shall be mounted with an air gap between it and the air bath. It may be attached to the air bath by means of three screws and spacing bushings. The bushings should be of proper thickness to define an air gap of 4.8 mm (3/16 in.), and they shall be not more than 9.5 mm (3/8 in.) in diameter.

A2. MANUFACTURING STANDARDIZATION OF THERMOMETER AND FERRULE

A2.1 The low-range thermometer, which conforms also to the specification for the cup thermometer in the tag closed tester (Test Method D 56) and which frequently is fitted with a metal ferrule intended to fit the collar on the cover of the tag flash tester, can be supplemented by an adapter (Fig. A2.1) to be used in the larger diameter collar of the Pensky-Martens apparatus. Differences in dimensions of these collars, which do

not affect test results, are a source of unnecessary trouble to manufacturers and suppliers of instruments, as well as to users.

A2.2 Dimensional requirements are shown in Fig. A2.1. Conformity to these requirements is not mandatory, but is desirable to users as well as suppliers of Pensky-Martens testers.

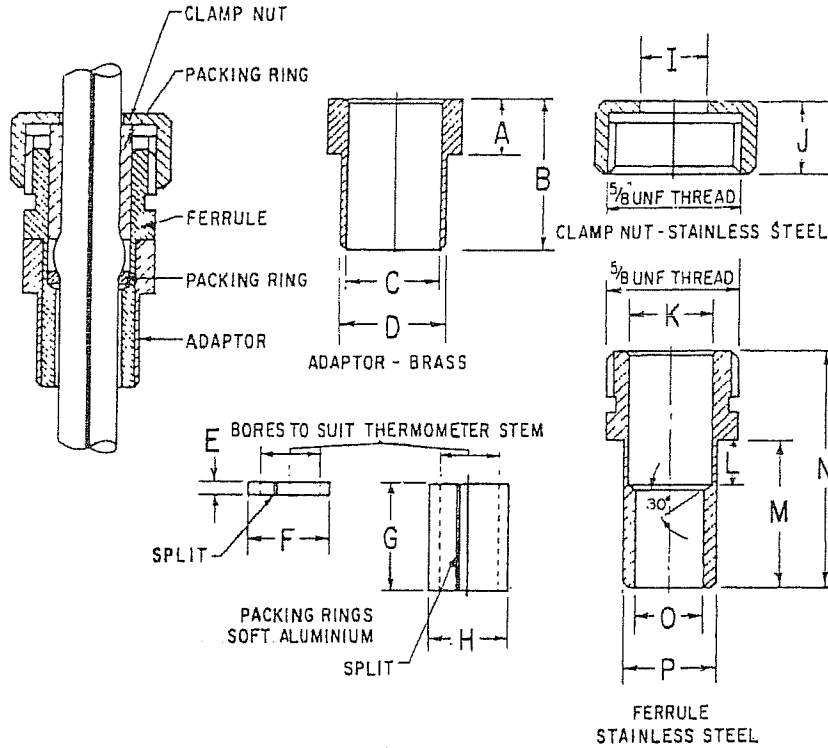

	mm		(in.)	
	min	max	(min)	(max)
A	6.20	8.50	(0.244)	(0.256)
B	17.0	18.0	(0.67)	(0.71)
C	9.80	9.85	(0.386)	(0.388)
D	11.92	12.24	(0.469)	(0.482)
E	1.40	1.65	(0.055)	(0.065)
F	8.56	8.61	(0.337)	(0.339)
G	12.4	13.0	(0.49)	(0.57)
H	8.56	8.61	(0.337)	(0.339)
I	8.1	8.6	(0.32)	(0.34)
J	9.9	10.7	(0.39)	(0.42)
K	8.64	8.69	(0.340)	(0.342)
L	5.1	5.6	(0.20)	(0.22)
M	17.0	17.5	(0.67)	(0.69)
N	27.4	28.2	(1.08)	(1.11)
O	7.11	7.16	(0.280)	(0.282)
P	9.73	9.78	(0.383)	(0.385)

FIG. A2.1 Dimensions for Thermometer Adapter, Ferrule, and Packing Ring

A3. THERMOMETER SPECIFICATIONS

A3.1 See Fig. A3.1 and Tables A3.1-A3.4.

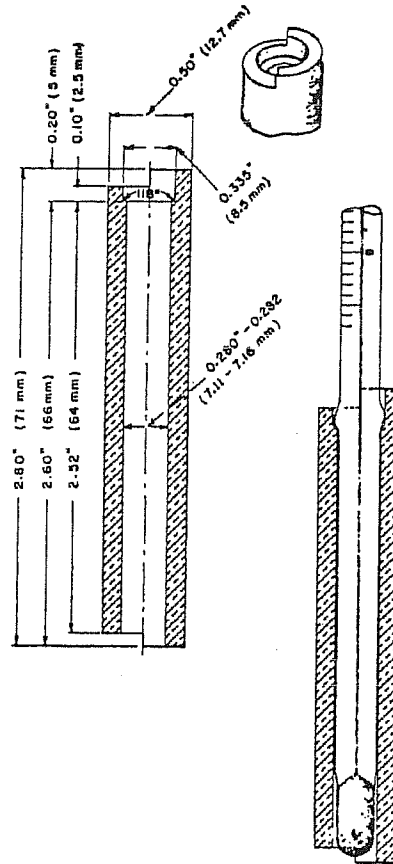

FIG. A3.1 Test Gage for Checking Enlargements on Thermometers

TABLE A3.1 IP Thermometer Specifications

NOTE—The stem shall be made with an enlargement having a diameter of 1.5 to 2.0 mm greater than the stem and a length of 3 to 5 mm, the bottom of the enlargement being 64 to 66 mm from the bottom of the bulb. These dimensions shall be measured with the test gage shown in Fig. A3.1.

Name	IP 15C	IP 16C	IP 101C
	Pensky-Martens Low	Pensky-Martens High	Pensky-Martens Medium
Range	-5 to + 110°C	90 to 370°C	20 to 150°C
Graduation	0.5°C	2°C	1°C
Immersion, mm	57	57	57
Overall length ±5 mm	290	280 ± 10	290
Stem diameter, mm	6.0 to 7.0	6.0 to 7.0	6.0 to 7.0
Bulb shape	cylindrical	cylindrical	cylindrical
Bulb length, mm	9 to 13	7 to 10	9 to 13
Bulb diameter, mm	not less than 5.5 and not greater than stem	not less than 4.5 and not greater than stem	not less than 5.5 and not greater than stem
Length of graduated portion, mm	140 to 175	143 to 180	140 to 175
Distance bottom of bulb to, mm	0°C 85 to 95	90°C 80 to 90	20°C 85 to 95
Longer lines at each	1 and 5°C	10 and 20°C	5°C
Figured at each	5°C	20°C	5°C
Expansion chamber	required	required	required
Top finish	ring	ring	ring
Scale error not to exceed ±	0.5°C	1 to 260°C 2°C above 260°C	1°C
See notes	1 and Table A3.2 for emergent stem temperatures	1 and Table A3.2 for emergent stem temperatures	1 and Table A3.2 for emergent stem temperatures

TABLE A3.2 Specifications for ASTM Thermometers
 All dimensions are in millimetres.
 See Table A3.3 for Standardization Temperature.

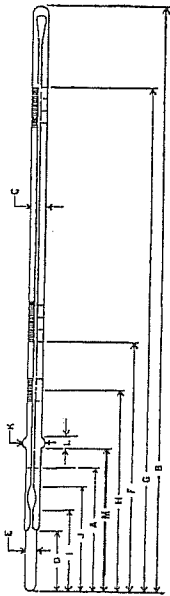

ASTM Number and Name	Range	For Test at	Im-mer-sion	Graduations			Scale Error, max	Special In-scrip-tion	Expan-sion Cham-ber	Total Length ±5	Stem OD	Bulb		Scale Location				Ice Point Scale		Contraction Chamber		Stem Enlargement		
				Sub-divisions	Long Lines at Each	Num-ber at Each						Length	OD	Bot-tom of Bulb to Line at	Dis-tance	Bot-tom of Bulb to Line at	Dis-tance	Bot-tom of Bulb to Ice Point	Dis-tance to Bot-tom, min	Dis-tance to Top, max	OD	Length	Dis-tance to Bot-tom	M
9C-62	-5 to +110°C		57	0.5°C	1°C	5°C	0.5°C	ASTM	160°C	287	6.0	9.0	not greater than stem	0°C	85	221	H					7.5	2.5	64
Pensky-Mardens Low-Range Tag Closed Tester 9F-62	(20 to 230°F)			1°F	5°F	10°F	1°F	9C or 9F 57 mm IMM	320°F		to 7.0	to 13		32°F	98	237						to 8.5	to 5.0 ^A	to 66
10C-62 Pensky-Mardens High-Range 10F-62	(200 to 700°F)		57	2°C	10°C	20°C	^B	ASTM 10C or 10F 57 mm IMM	^C	287	6.0 to 7.0	8.0 to 10.0	4.5 to 6.0	110°C	86 to 99	227 to 245						7.5 to 8.5	2.5 to 5.0 ^A	64 to 66

^A The length of the enlargement, and the distance from the bottom of the enlargement to the bottom of the bulb shall be measured with the test gage shown in Fig. A3.1.
^B Scale error: 1°C up to 260°C; 2°C over 260°C.
^C An expansion chamber is provided for relief of gas pressure to avoid distortion of the bulb at higher temperatures. It is not for the purpose of joining mercury separations; and under no circumstances should the thermometer be heated above the highest temperature reading.
^D Scale error: 2.5°F up to 500°F; 3.5°F over 500°F.

TABLE A3.3 Standardization Temperatures

NOTE—The emergent column temperatures are those attained when using the thermometers in the test equipment for which the thermometers were originally designed. In some cases these temperatures are markedly different from those realized during standardization.

Temperature	Average Temperature of Emergent Column	Temperature	Average Temperature of Emergent Column	Temperature	Average Temperature of Emergent Column	Temperature	Average Temperature of Emergent Column
Thermometer 9C (-5 to + 100°C)		Thermometer 9F (20 to 230°F)		Thermometer 10C (90 to 370°C)		Thermometer 10F (200 to 700°F)	
0°C	19°C	32°F	66°F	100°C	61°C	212°F	141°F
35°C	28°C	100°F	86°F	200°C	71°C	390°F	159°F
70°C	40°C	160°F	106°F	300°C	87°C	570°F	180°F
105°C	50°C	220°F	123°F	370°C	104°C	700°F	220°F
IP 15C (-7 to 110°C)		IP 15F (20 to 230°F)		IP 16C (90 to 370°C)		IP 16F (20 to 700°F)	
0°C	19°C	32°F	66°F	100°C	61°C	200°F	140°F
20°C	20°C	70°F	70°F	150°C	65°C	300°F	149°F
40°C	31°C	100°F	86°F	200°C	71°C	400°F	160°F
70°C	40°C	150°F	104°F	250°C	78°C	500°F	175°F
100°C	48°C	212°F	118°F	300°C	87°C	600°F	195°F
				350°C	99°C	700°F	220°F

TABLE A3.4 Specifications for Medium-Range Pensky-Martens

ASTM No. 88F (88C) Vegetable Oil Flash Thermometer		Medium-Range Pensky-Martens	
Name		5	
Reference Fig. No.			
Range		10–200°C	50–392°F
For test at			
A Immersion, mm		57	
Graduations:			
Subdivisions		0.5°C	1°F
Long lines at each		1°C and 5°C	5°F
Numbers at each		5°C	10°F
Scale error, max		0.5°C	1°F
Special inscription		ASTM 88F (88C) 57 mm IMM	
Expansion chamber:			
Permit heating to		205°C	400°F
B Total length, mm		285 to 295	
C Stem OD, mm		6.0 to 7.0	
D Bulb length, mm		8.0 to 12.0	
E Bulb OD, mm		>4.5 and <stem ^A	
Scale location:			
Bottom of bulb to line at		20°C	68°F
F Distance, mm		80 to 90	
G Length of graduated portion, mm		145 to 180	
Ice-point scale:			
Range			
H Bottom of bulb to ice-point, mm			
Contraction chamber:			
I Distance to bottom, min, mm			
J Distance to top, max, mm			
Stem enlargement:			
K OD, mm		7.5 to 8.5	
L Length, mm		2.5 to 5.0 ^A	
M Distance to bottom, mm		64 to 66	

^A Bulb OD shall be greater than 4.5 mm and less than the outside diameter of the stem (C).

A4. VERIFICATION OF APPARATUS PERFORMANCE

A4.1 *Certified Reference Material (CRM)*—CRM is a stable, pure (99 + mole % purity) hydrocarbon or other stable petroleum product with a method-specific flash point established by a method-specific interlaboratory study following ASTM RR:D02-1007 guidelines¹¹ or ISO Guide 34 and 35.

A4.1.1 Values of the flash point corrected for barometric pressure for some reference materials and their typical limits are given in Table A4.1¹² (see Note A4.1). Suppliers of CRMs

TABLE A4.1 D 93 Typical Flash Point Values and Typical Limits for CRM

NOTE—Supporting data for the interlaboratory study to generate the flash point in Table A4.1 can be found in research report RR:S15-1010.¹²

Hydrocarbon	Purity, mole %	Flash Point, °C	Limits, °C
<i>n</i> -decane	99 +	52.8	±2.3
<i>n</i> -undecane	99 +	68.7	±3.0
<i>n</i> -tetradecane	99 +	109.3	±4.8
<i>n</i> -hexadecane	99 +	133.9	±5.9

¹² Supporting data have been filed at ASTM International Headquarters and may be obtained by requesting Research Report RR: S15-1010.

will provide certificates stating the method-specific flash point for each material of the current production batch. Calculation of the limits for these other CRMs can be determined from the reproducibility value of these test methods, reduced by interlaboratory effect and then multiplied by 0.7. See Research Report RR:S15-1008.¹⁰

NOTE A4.1—Materials, purities, flash point values, and limits stated in Table A4.1 were developed in an ASTM interlaboratory program to determine suitability of use for verification fluids in flash point test methods. Other materials, purities, flash point values, and limits can be suitable when produced according to the practices of ASTM RR:D02-1007 or ISO Guides 34 and 35. Certificates of performance of such materials should be consulted before use, as the flashpoint value will vary dependent on the composition of each CRM batch.

A4.2 *Secondary Working Standard (SWS)*—SWS is a stable, pure (99 + mole % purity) hydrocarbon, or other petroleum product whose composition is known to remain appreciably stable.

A4.2.1 Establish the mean flash point and the statistical control limits (3σ) for the SWS using standard statistical techniques. (See ASTM MNL 7).¹³

¹³ *Manual on Presentation of Data and Control Chart Analysis*, ASTM MNL, 6th ed., ASTM International, W. Conshohocken, 1990.

APPENDIXES

(Nonmandatory Information)

X1. FLASH POINT MASKING PHENOMENON

X1.1 A condition during flash point testing can occur with certain mixtures whereby the nonflammable component of the sample tends to inert the vapor space above the liquid, thus preventing a flash. Under this condition, the flash point of the material is masked resulting in the reporting of incorrect high flash point or no flash point.

X1.2 This flash point masking phenomenon most frequently occurs with ignitable liquids that contain certain halogenated hydrocarbons such as dichloromethane (methylene chloride) and trichloroethylene.

X1.3 Under this condition, no distinct flash as defined in 3.1.3 of these test methods is observed. Instead a significant enlargement of the test flame and a change in the color of the

test flame from blue to yellow-orange laminar flame is observed.

X1.4 Under this condition, continued heating and testing for flash point at temperatures above ambient temperature, have resulted in significant burning of the ignitable vapor outside the test cup, often above the test flame. This can be a potential fire hazard if not recognized.

X1.5 It is recommended that if this condition is encountered during the flash point testing of these type of materials, testing should be discontinued.

X1.6 Further commentaries regarding flash point test and flammability of mixtures can be found in Test Method E 502.

X2. FLASH POINT TEST AND FLAMMABILITY OF MIXTURES

X2.1 While the flash point can be used to indicate the flammability of liquid materials for certain end uses, flash point does not represent the minimum temperature at which a material can evolve flammable vapors.

X2.2 There are instances with pure materials where the absence of a flash point does not ensure freedom from flammability. Included in this category are materials that require large diameters for flash propagation, such as trichloroethylene. This material will not propagate a flame in apparatus the size of a flash point tester, however, its vapors are flammable and will burn when ignited in apparatus of adequate size.

X2.3 When a liquid contains flammable and nonflammable

components, there are cases where this liquid can evolve flammable vapors under certain conditions and yet will not exhibit a close-cup flash point. This phenomenon is noted when a nonflammable component is sufficiently volatile and present in sufficient quantity to inert the vapor space of the closed cup, thus preventing a flash. In addition, there are certain instances where an appreciable quantity of the nonflammable component will be present in the vapor, and the material will exhibit no flash point.

X2.4 Liquids containing a highly volatile nonflammable component or impurity, which exhibit no flash point because of the influence of the nonflammable material, may form flammable mixtures if totally flash vaporized in air in the proper proportions.

SUMMARY OF CHANGES

Subcommittee D02.08 has identified the location of selected changes to this standard since the last issue (D 93-02) that may impact the use of this standard.

- (1) Added a paragraph to the Introduction about flash point values being dependent on the test procedure used. (2) Deleted Note 2 and renumbered the notes.

ASTM International takes no position respecting the validity of any patent rights asserted in connection with any item mentioned in this standard. Users of this standard are expressly advised that determination of the validity of any such patent rights, and the risk of infringement of such rights, are entirely their own responsibility.

This standard is subject to revision at any time by the responsible technical committee and must be reviewed every five years and if not revised, either reapproved or withdrawn. Your comments are invited either for revision of this standard or for additional standards and should be addressed to ASTM International Headquarters. Your comments will receive careful consideration at a meeting of the responsible technical committee, which you may attend. If you feel that your comments have not received a fair hearing you should make your views known to the ASTM Committee on Standards, at the address shown below.

This standard is copyrighted by ASTM International, 100 Barr Harbor Drive, PO Box C700, West Conshohocken, PA 19428-2959, United States. Individual reprints (single or multiple copies) of this standard may be obtained by contacting ASTM at the above address or at 610-832-9585 (phone), 610-832-9555 (fax), or service@astm.org (e-mail); or through the ASTM website (www.astm.org).

APPENDIX E



Designation: D 95 – 05^{ε1}

An American National Standard

American Association State
Highway Transportation Standard
AASHTO No. T55



Designation: Manual of Petroleum Measurement Standards (MPMS), Chapter 10.5

Designation: 74/82 (88)

Standard Test Method for Water in Petroleum Products and Bituminous Materials by Distillation¹

This standard is issued under the fixed designation D 95; the number immediately following the designation indicates the year of original adoption or, in the case of revision, the year of last revision. A number in parentheses indicates the year of last reapproval. A superscript epsilon (ϵ) indicates an editorial change since the last revision or reapproval.

This standard has been approved for use by agencies of the Department of Defense.

^{ε1} Note—Table 4 formatting and the last sentence of 7.1 were updated editorially in August 2005.

1. Scope*

1.1 This test method covers the determination of water in the range from 0 to 25 % volume in petroleum products, tars, and other bituminous materials by the distillation method.

NOTE 1—Volatile water-soluble material, if present, may be measured as water.

1.2 The specific products considered during the development of this test method are listed in Table 1. For bituminous emulsions refer to Test Method D 244. For crude oils, refer to Test Method D 4006 (API *MPMS* Chapter 10.2).

NOTE 2—With some types of oil, satisfactory results may be obtained from Test Method D 1796 (API *MPMS* Chapter 10.6).

1.3 The values stated in SI units are to be regarded as the standard. The values in parentheses are for information only.

1.4 *This standard does not purport to address all of the safety concerns, if any, associated with its use. It is the responsibility of the user of this standard to establish appropriate safety and health practices and determine the applicability of regulatory limitations prior to use.* For specific hazard statements, see Section 6.

2. Referenced Documents

2.1 *ASTM Standards*:²

D 244 Test Methods for Emulsified Asphalts

D 1796 Test Method for Water and Sediment in Fuel Oils by the Centrifuge Method (Laboratory Procedure) (API *MPMS* Chapter 10.6)

D 4006 Test Method for Water in Crude Oil by Distillation (API *MPMS* Chapter 10.2)

D 4057 Practice for Manual Sampling of Petroleum and Petroleum Products (API *MPMS* Chapter 8.1)

D 4177 Practice for Automatic Sampling of Petroleum and Petroleum Products (API *MPMS* Chapter 8.2)

D 5854 Practice for Mixing and Handling of Liquid Samples of Petroleum and Petroleum Products (API *MPMS* Chapter 8.3)

E 123 Specification for Apparatus for Determination of Water by Distillation

2.2 *API Standards*:³

MPMS Chapter 8.1 Manual Sampling of Petroleum and Petroleum Products (ASTM Practice D 4057)

MPMS Chapter 8.2 Automatic Sampling of Petroleum and Petroleum Products (ASTM Practice D 4177)

MPMS Chapter 8.3 Mixing and Handling of Liquid Samples of Petroleum and Petroleum Products (ASTM Practice D 5854)

MPMS Chapter 10.2 Determination of Water in Crude Oil by the Distillation Method (ASTM Test Method D 4006)

MPMS Chapter 10.6 Test Method for Water and Sediment in Fuel Oils by the Centrifuge Method (Laboratory Procedure) (ASTM Test Method D 1796)

3. Terminology

3.1 *Definitions*:

¹ This test method is under the jurisdiction of ASTM Committee D02 on Petroleum Products and Lubricants and the API Committee on Petroleum Measurement, and is the direct responsibility of Subcommittee D02.02 /COMQ, the joint ASTM-API Committee on Static Petroleum Measurement.

Current edition approved June 1, 2005. Originally approved in 1921. Last previous edition approved in 1999 as D 95–99¹.

² For referenced ASTM standards, visit the ASTM website, www.astm.org, or contact ASTM Customer Service at service@astm.org. For *Annual Book of ASTM Standards* volume information, refer to the standard's Document Summary page on the ASTM website.

³ Published as Manual of Petroleum Measurement Standards. Available from the American Petroleum Institute (API), 1220 L St., NW, Washington, DC 20005.

*A Summary of Changes section appears at the end of this standard.

Copyright © ASTM International, 100 Barr Harbor Drive, PO Box C700, West Conshohocken, PA 19428-2959, United States.

Copyright by ASTM Int'l (all rights reserved); Tue Sep 19 11:23:39 EDT 2006
Reproduction authorized per License Agreement with Larry A Doyle (Cliff Berry Inc);

3.1.1 *bituminous material, n*—in petroleum technology, a black or dark-colored very viscous liquid or semi-solid composed principally of high molecular weight condensed aromatic, or naphthenic compounds, or both.

4. Summary of Test Method

4.1 The material to be tested is heated under reflux with a water-immiscible solvent, which co-distills with the water in the sample. Condensed solvent and water are continuously separated in a trap, the water settling in the graduated section of the trap and the solvent returning to the still.

5. Significance and Use

5.1 A knowledge of the water content of petroleum products is important in the refining, purchase, sale, and transfer of products.

5.2 The amount of water as determined by this test method (to the nearest 0.05 or 0.1 volume %, depending on the trap size used) may be used to correct the volume involved in the custody transfer of petroleum products and bituminous materials.

5.3 The allowable amount of water may be specified in contracts.

6. Solvent-Carrier Liquid

6.1 A solvent-carrier liquid appropriate to the material being tested (see Table 1) shall be used.

6.1.1 *Aromatic Solvent*—The following aromatic solvents are acceptable:

6.1.1.1 *Industrial Grade Xylene*—(Warning—Flammable. Vapor harmful.)

6.1.1.2 A blend of 20 volume % industrial grade toluene and 80 volume % industrial grade xylene. (Warning—Flammable. Vapor harmful.)

6.1.1.3 *Petroleum Naphtha or Coal Tar Naphtha*, free of water, yielding not more than 5% distillates at 125°C (257°F) and not less than 20% at 160°C (320°F) and with a relative density (specific gravity) not lower than 0.8545 at 15.56/15.56°C (60/60°F). (Warning—Extremely flammable. Harmful if inhaled. Vapors may cause fire.)

6.1.2 *Petroleum Distillate Solvent*—A petroleum distillate solvent, 5% boiling between 90 and 100°C (194 and 212°F) and 90% distilling below 210°C (410°F), shall be used. Percent may be determined by mass or by volume. (Warning—Flammable. Vapor harmful.)

6.1.3 *Volatile Spirits Solvent*—The following volatile spirits solvents are acceptable:

6.1.3.1 *Petroleum Spirit*, with a boiling range from 100 to 120°C (212 to 248°F). (Warning—Flammable. Vapor harmful.)

TABLE 1 Type of Solvent-Carrier Liquid Versus Material to Be Tested

Type of Solvent-Carrier Liquid	Material to be Tested
Aromatic	asphalt, tar, coal tar, water gas tar, road tar, cut-back bitumin, liquid asphalt, tar acid
Petroleum distillate	road oil, fuel oil, lubricating oil, petroleum sulfonates
Volatile spirits	lubricating grease

6.1.3.2 *Iso-octane*, of 95% purity or better. (Warning—Extremely flammable. Harmful if inhaled. Vapors may cause fire.)

6.2 *Solvent Blank*—The water content of the solvent shall be determined by distilling an equivalent amount of the same solvent used for the test sample in the distillation apparatus and testing as outlined in Section 10. The blank shall be determined to the nearest scale division and used to correct the volume of water in the trap in Section 11.

7. Apparatus

7.1 *General*—The apparatus comprises a glass or metal still, a heater, a reflux condenser, and a graduated glass trap. The still, trap, and condenser may be connected by any suitable method that produces a leakproof joint. Preferred connections are ground joints for glass and O-rings for metal to glass. Typical assemblies are illustrated in Fig. 1, Fig. 2, and Fig. 3. The stills and traps should be chosen to cover the range of materials and water contents expected. On assembly, care shall be taken to prevent the joints from freezing or sticking. Always apply a very thin film of stopcock grease to prevent the glassware joints from seizing.

7.2 *Still*—A glass or metal vessel with a short neck and suitable joint for accommodating the reflux tube of the trap shall be used. Vessels of 500, 1000, and 2000-mL nominal capacity have proved satisfactory.

7.3 *Heater*—A suitable gas burner or electric heater may be used with the glass still. A gas ring burner with ports on the inside circumference shall be used with the metal still. The gas ring burner shall be of such dimensions that it may be moved up and down the vessel when testing materials that are likely to foam or solidify in the still.

7.4 *Glassware*—Dimensions and descriptions of typical glassware for use in this test method are provided in Specification E 123.

NOTE 3—Instead of standardizing on a particular apparatus specification with respect to dimensions and style, a given apparatus will be deemed satisfactory when accurate results are obtained by the standard

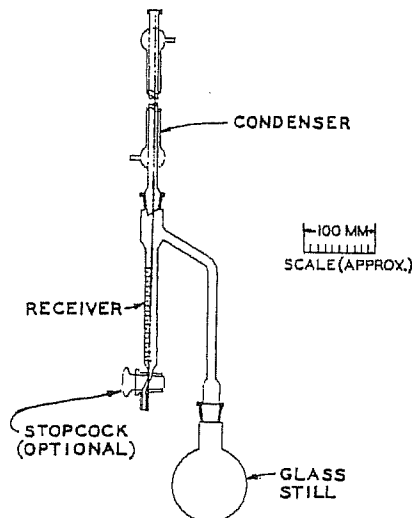

FIG. 1 Typical Assembly with Glass Still

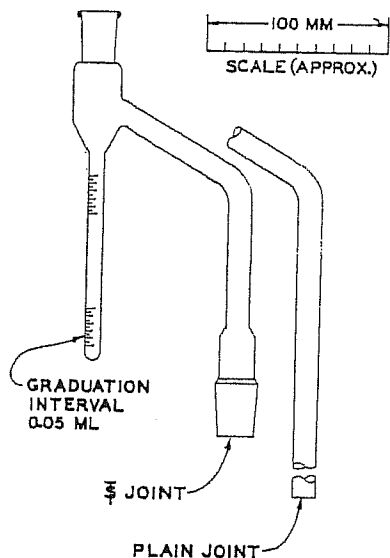

FIG. 2 Two-millilitre Receiver Showing Alternative Connections to Glass Still

addition technique described in Section 9.

8. Sampling

8.1 Sampling is defined as all steps required to obtain an aliquot of the contents of any pipe, tank, or other system and to place the sample into the laboratory test container. Only representative samples obtained as specified in Practices D 4057 (API *MPMS* Chapter 8.1) and D 4177 (API *MPMS* Chapter 8.2) shall be used for this test method.

8.2 The size of the test portion should be based on the expected water content of the sample, such that the water yield does not exceed the capacity of the trap (unless a trap with a stopcock is used permitting excess water to be withdrawn into a graduated cylinder).

8.3 Practice D 5854 (API *MPMS* Chapter 8.3) contains information on sampling and homogenization efficiency of unknown mixers. This test method should not be followed without strict adherence to Practice D 5854 (API *MPMS* Chapter 8.3).

9. Verification

9.1 The accuracy of the graduation marks on the trap shall be certified or verified, using only national or international standards, such as National Institute of Standards and Technology (NIST)⁴ traceable equipment. Verification shall be with a traceable 5 mL Micro Burette or Micro Pipette, readable to the nearest 0.01 mL.

9.1.1 In styles A, B, C, and D, as specified in Table 2 (Table 1 in Specification E 123), each subdivision (that is, 0.1 mL through 1.0 mL) in the conical portion of the tube shall be verified. Thereafter, each major subdivision (that is, 2.0 mL, 3.0 mL, 4.0 mL, and up to the total volume of the trap) shall be verified.

⁴ National Institute of Standards and Technology, U.S. Department of Commerce, Gaithersburg, MD 20899.

9.1.2 In styles E and F, as specified in Table 2, each major subdivision (0.1 mL, 1.0 mL, 2.0 mL, 4.0 mL, and 5.0 mL in the case of Style E; 0.05 mL, 0.5 mL, 1.0 mL, 1.5 mL, and 2.0 mL in the case of Style F) shall be verified.

9.2 The entire glassware assembly shall be verified prior to first use and at a regular frequency thereafter as follows.

9.2.1 Put 400 mL of dry (0.02 % water maximum) xylene or the solvent to be utilized in the analysis of unknown samples into the apparatus and test in accordance with Section 10. When complete, discard the contents of the trap and add the volume of water as specified as first test in Table 3 directly to the distillation flask and test in accordance with Section 10.

9.2.2 Repeat the test in 9.2.1, and add the volume specified as second test in Table 3 directly to the flask. The assembly of the apparatus is satisfactory only if the trap readings are within the tolerances specified in Table 3.

9.3 A reading outside the permissible limits suggests a malfunction resulting from vapor leaks, too rapid boiling, inaccuracies in calibration of the trap, or ingress of extraneous moisture. Eliminate these factors before repeating the verification.

10. Procedure

NOTE 4—The precision of this test method will be affected by water droplets adhering to surfaces in the apparatus and therefore not settling into the water trap to be measured. To minimize the problem, all apparatus must be cleaned chemically at least daily to remove surface films and debris, which hinder free drainage of water in the test apparatus. More frequent cleaning is recommended if the nature of samples being run causes persistent contamination.

10.1 Measure a suitable amount of sample to an accuracy of $\pm 1\%$ and transfer it to the still.

10.2 Measure ordinary liquid samples in a graduated cylinder of an appropriate size. Rinse the material adhering to the cylinder with one 50-mL and two 25-mL portions of the solvent-carrier liquid (see Section 6 and Table 1). Drain the cylinder thoroughly after the sample transfer and each rinsing.

10.3 Weigh solid or viscous materials directly into the still and add 100 mL of the selected solvent-carrier liquid. In cases of material with a low-water content when large samples must be used, a solvent-carrier liquid volume in excess of 100 mL may be necessary.

10.4 Glass beads or other boiling aids may be added, if necessary, to reduce bumping.

10.5 Assemble the components of the apparatus, as illustrated in Fig. 1, Fig. 2, and Fig. 3, choosing the trap in accordance with the expected water content of the sample and making all connections vapor and liquid tight. If a metal still with a removable cover is used, insert a gasket of heavy paper, moistened with solvent, between the still body and the cover. The condenser tube and trap must be chemically clean to ensure free drainage of water into the bottom of the trap. Insert a loose cotton plug in the top of the condenser to prevent condensation of atmospheric moisture inside it. Circulate cold water through the jacket of the condenser.

10.6 Apply heat to the still, adjusting the rate of boiling so that condensed distillate discharges from the condenser at the rate of two to five drops per second. If the metal still is used, start heating with the ring burner about 76 mm (3 in.) above the

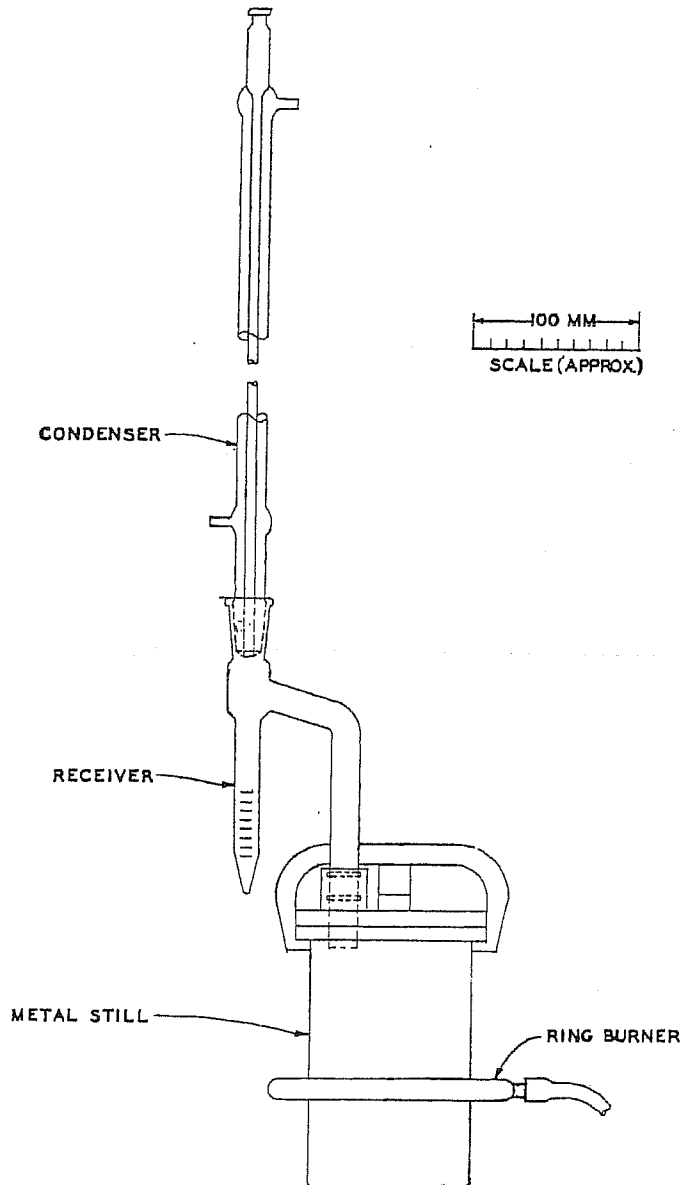

NOTE—Trap shall be 15 to 16 mm in inside diameter.
FIG. 3 Typical Assemblies with Metal Still

TABLE 2 Specifications and Sizes of Traps

Description							
Style	Top of Graduated Tube	Bottom of Graduated Tube	Bottom of Vapor Tube	Size of Trap mL	Range mL	Smallest Scale Division, mL	Scale Error Maximum, mL
A	ST Joint	Conical	ST Joint	10	0 to 1.0	0.1	0.05
B	ST Joint	Conical	ST Joint	25	>1.0 to 10.0	0.2	0.1
C	ST Joint	Conical	Plain	25	0 to 1.0	0.1	0.05
D	ST Joint	Conical	Plain	25	>1.0 to 25	0.2	0.1
E	ST Joint	Round	ST Joint	5	1.0 to 25	0.2	0.1
				5	0 to 5.0	0.1	0.05
				10	0 to 5.0	0.05	0.025
F	ST Joint	Round	ST Joint	10	0 to 10.0	0.1	0.1
				2	0 to 2.0	0.05	0.025

TABLE 3 Permissible Limits in Millilitres

Capacity of Receiver at 20°C		Volume of Water Added to Flask at 20°C	Permissible Limits for Recovered Water at 20°C
Round trap 2	1 st Test	1	1 ± 0.05
	2 nd Test	1.9	1.9 ± 0.05
5 (0.05 mL subdivisions)	1 st Test	1	1 ± 0.05
	2 nd Test	4.5	4.5 ± 0.05
5 (0.1 mL subdivisions)	1 st Test	1	1 ± 0.1
	2 nd Test	4.5	4.5 ± 0.1
10	1 st Test	5	5 ± 0.1
	2 nd Test	9	9 ± 0.1
Conical trap 10	1 st Test	1	1 ± 0.1
	2 nd Test	9	9 ± 0.2
25	1 st Test	12	12 ± 0.2
	2 nd Test	24	24 ± 0.2

bottom of the still and gradually lower the burner as the distillation proceeds. Continue distillation until no water is visible in any part of the apparatus except in the trap and the volume of water in the trap remains constant for 5 min. If there is a persistent ring of water in the condenser tube, carefully increase the rate of distillation or cut off the condenser water for a few minutes.

10.7. When the evolution of water is complete, allow the trap and contents to cool to room temperature. Dislodge any drops of water adhering to the sides of the trap with a glass or polytetrafluoroethylene (PTFE) rod or other suitable means and transfer them to the water layer. Read the volume of the water in the trap to the nearest scale division.

10.8. A solvent blank shall be established, as outlined in 6.2.

11. Calculation

11.1. Calculate the water in the sample, as weight or volume percent, in accordance with the basis on which the sample was taken, as follows:

11.1.1 Water, % (V/V) =

$$\frac{(\text{Volume in water trap, mL}) - (\text{Water in solvent blank, mL})}{\text{Volume in test sample, mL}} \times 100 \quad (1)$$

11.1.2 Water, % (V/m) =

$$\frac{(\text{Volume of water in trap, mL}) - (\text{Water in solvent blank, mL})}{\text{Mass of test sample, g}} \times 100 \quad (2)$$

12. Report

12.1 Report the results as the water content to the nearest 0.05% if the 2-mL receiver has been used and to the nearest 0.1% if the 10-mL or 25-mL receiver has been used and to the nearest subdivision if a 5-mL receiver has been used with a 100-mL or 100-g sample.

13. Precision and Bias

13.1 *Precision*—The criteria described in 13.1.1 and 13.1.2 should be used to judge the acceptability of results when using the 10 or 25-mL traps. The precision when using the 2-mL trap or a 5-mL trap has not been established.

NOTE 5—Practice D 6300 was not used in obtaining precision data.

13.1.1 *Repeatability*—The difference between successive test results, obtained by the same operator with the same apparatus under constant operating conditions on identical test material, would, in the long run, in the normal and correct operation of the test method, exceed the values in Table 4 in only one case in twenty.

13.1.2 *Reproducibility*—The difference between two single and independent test results obtained by different operators working in different laboratories on identical test material, would, in the long run, in the normal and correct operation of the test method, exceed the values in Table 4 in only one case in twenty.

13.2 *Bias*—As there is no accepted reference material suitable for determining bias for the procedure described in this test method for measuring water in petroleum products and bituminous materials by distillation, no statement about bias is made.

14. Keywords

14.1 bituminous materials; distillation; petroleum products; solvent carrier liquid; water by distillation; water content

TABLE 4 Precision

Type	Water Collected, mL	Difference, mL
Repeatability	0.0–1.0	0.1
	1.1–25	0.1 mL or 2 % of the mean, whichever is greater
Reproducibility	0.0–1.0	0.2
	1.1–25	0.2 mL or 10 % of the mean, whichever is greater

SUMMARY OF CHANGES

Subcommittee D02.02 has identified the location of selected changes to this standard since the last issue (D 95–99^{e1}) that may impact the use of this standard.

- (1) Added the use of a 5-mL receiver flask to 5.2, 12.1, 13.1, and Tables 2–4. (3) Replaced the term “standardization” with “verification” in Section 9.
- (2) Added Section 3, Terminology.

ASTM International takes no position respecting the validity of any patent rights asserted in connection with any item mentioned in this standard. Users of this standard are expressly advised that determination of the validity of any such patent rights, and the risk of infringement of such rights, are entirely their own responsibility.

This standard is subject to revision at any time by the responsible technical committee and must be reviewed every five years and if not revised, either reapproved or withdrawn. Your comments are invited either for revision of this standard or for additional standards and should be addressed to ASTM International Headquarters. Your comments will receive careful consideration at a meeting of the responsible technical committee, which you may attend. If you feel that your comments have not received a fair hearing you should make your views known to the ASTM Committee on Standards, at the address shown below.

This standard is copyrighted by ASTM International, 100 Barr Harbor Drive, PO Box C700, West Conshohocken, PA 19428-2959, United States. Individual reprints (single or multiple copies) of this standard may be obtained by contacting ASTM at the above address or at 610-832-9585 (phone), 610-832-9555 (fax), or service@astm.org (e-mail); or through the ASTM website (www.astm.org).