



State of Florida  
DEPARTMENT OF ENVIRONMENTAL REGULATION

For Routing To Other Than The Addressee	
To: _____	Location: _____
To: _____	Location: _____
To: _____	Location: _____
From: _____	Date: _____

# Interoffice Memorandum

TO: Rick Garrity

THRU: Bill Kutash *WR 3/5/92*

FROM: Bill Crawford *WC 3/4/92*

SUBJECT: Safety Kleen Corporation  
EPA Region IV Initiative  
Southwest Florida District Involvement

*3/5*  
*Book*  
*the*  
*fb*

*H029-158820*  
*AI, 6-h*

As part of the regionwide initiative the Southwest district conducted a compliance inspection of the permitted and operating facility at 24th Street and 56th Avenue in Tampa. The inspection found the facility to be in compliance with State and Federal regulations at the time of the inspection.

An inoperative facility on Manhattan Street has submitted a closure permit application that is nearly complete , and a closure permit should be issued before June 1992.

TO: SOUTHWEST TAMPA

MAR-02-'92 MON 16:22 ID: DER WASTE MGMT TFL FAX NO: (904) 922-4939

#630 P01

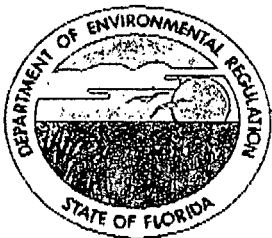

# Florida Department of Environmental Regulation

Twin Towers Office Bldg. • 2600 Blair Stone Road • Tallahassee, Florida 32399-2400

Lawton Chiles, Governor

Carol M. Browner, Secretary

*3/2*  
Bill  
*any in our district?*

## FAX TRANSMITTAL LETTER

DATE: 3/2/92

TO: Southwest Dist

AGENCY: \_\_\_\_\_

TELEPHONE: \_\_\_\_\_

NUMBER OF PAGES (INCLUDING COVER SHEET) 2-1

FROM: T. Thompson

AGENCY: DER

*Re Bill C.*  
*Brief Note to*  
*Secretary on*  
*our involvement*

If any of the pages are not clearly received, please call IMMEDIATELY,

Phone No. 488-0300

SENDERS NAME: \_\_\_\_\_

COMMENTS:

*Mike -  
Place the Dist. Threat South*



United States  
Environmental Protection  
Agency

Region IV  
Office of Public Affairs  
345 Courtland St. NE  
Atlanta, Georgia 30365



# Environmental News

(404) 347-3004

## EPA ENFORCEMENT INITIATIVE TARGETS SAFETY KLEEN CORPORATION FOR HAZARDOUS WASTE VIOLATIONS

The U.S. Environmental Protection Agency, Region IV, and the States of Florida, Georgia, Kentucky, North Carolina, South Carolina and Tennessee, announced today that fifteen enforcement actions have been taken against nineteen Safety Kleen Corporation (SKC) facilities in the Southeast. This regionwide initiative addresses the Corporation's repeated failure to comply with the Resource Conservation and Recovery Act (RCRA). EPA launched this federal/state initiative when several states expressed concern about numerous violations of RCRA at various SKC facilities. EPA and the states together have filed administrative enforcement actions totalling \$607,398 in penalties against the Safety Kleen Corporation.

Of the actions filed, thirteen were taken by the states under RCRA. Four of the enforcement actions were filed prior to today's announcement.

"The initiative announced today is part of an intense effort to identify facilities which do not comply with the nation's hazardous waste laws," said Donald Guinyard, EPA Regional Waste Management Division Director. "By taking these cooperative enforcement actions, EPA and the states are sending a clear message of their commitment to vigorously enforce hazardous waste regulations."

Many of the cases allege that the facilities violated permit conditions, including but not limited to, conditions prohibiting operational changes without prior notification of the regulatory agency and without making appropriate modifications to the RCRA permit. Other cases allege that the facilities violated generator requirements including manifest requirements. This alleged violation includes transporting hazardous waste without a manifest and sending waste to a facility not designated on the manifest.

### EPA ENFORCEMENT-LEAD CASES

#### SKC, New Castle, Kentucky

Complaint and Compliance Order with a civil penalty assessment of \$65,625 for failure to respond in a timely manner to a RCRA 3007 Information Request.

#### SKC, Altamonte Springs, Florida

A Consent Order was signed on October 21, 1991. The facility failed to submit a RCRA Facility Investigation Report in a timely manner. The facility was required to pay a civil penalty of \$74,620.

Additionally, notices of technical inadequacy for submissions related to permits were issued to SKC for its Tampa and Port Charlotte, Florida and Lexington, Kentucky facilities.

**STATE ENFORCEMENT-LEAD CASES****Alabama**

Notices of Violations (NOVs) were issued to SKC facilities in Huntsville, Montgomery, Whistler, and Dolomite, Alabama. The facilities were cited for violations relating to the land restrictions requirements, waste analysis, container management requirements, personnel training and preparedness and prevention.

**Florida**

The state is filing a suit against SKC for violations at facilities in Port Charlotte, Altamonte Springs, Tallahassee, Miami, and Boynton Beach. The complaint alleges violations of security requirements and permit conditions, acceptance and shipment of wastes without manifests, construction of a hazardous waste tank without a permit, failure to make notification of a spill, and failure to maintain adequate inspection logs. Florida is seeking statutory penalties and an injunction ordering the facilities to comply with RCRA requirements.

**Georgia**

A Consent Order was signed on December 6, 1991, with SKC's Garden City, GA facility in response to 120 violations of manifest requirements. The company paid a \$50,000 fine.

**Kentucky**

A Demand Letter has been issued to SKC's Louisville, KY facility for violations of container management and storage requirements. The Demand Letter assesses a penalty of \$25,000 and requires the company to cease accepting waste not properly containerized, to properly containerize waste on-site, amend the facility's Part A Hazardous Waste Permit Application, and comply fully with all applicable environmental statutes and regulations.

**North Carolina**

Notices of Violations were issued to SKC facilities in Charlotte and High Point, NC.

**South Carolina**

A Consent Order with a \$39,000 penalty was issued to SKC's Florence Service Center for failure to submit a complete Part B Hazardous Waste Permit Application and failure to submit quarterly reports in a timely manner. SKC's Summerville facility entered into a Consent Order with South Carolina, agreeing to pay a civil penalty of \$13,400 for violations of manifest requirements.

**Tennessee**

A Commissioner's Order was filed against SKC's Knoxville facility for failure to comply with general operating requirements and assesses a penalty of \$225,503. A second order was filed against the Nashville facility for closure related violations and assesses a penalty of \$103,000.

-0-

February 28, 1992

CONTACT: Carl Terry, Press Office, 404/347-3004

UNITED STATES ENVIRONMENTAL PROTECTION  
REGION IV - ATLANTA, GEORGIA

D. E. R.

NOV - 8 1991

SOUTHWEST DISTRICT  
TAMPA

MEMORANDUM

DATE: ~~OCT~~ 28 1991

SUBJECT: Recommendation for Issuance of HSWA Portion of the  
Resource Conservation and Recovery Act (RCRA) Permit  
for Safety-Kleen Corporation's Tampa Facility  
EPA I.D. Number FLD 980 847 271

H029-158820

FROM: Douglas C. McCurry, Chief  
Waste Engineering Section  
RCRA and Federal Facilities Branch

AI, 6-1

TO: Donald J. Guinyard, Director  
Waste Management Division

THRU: James H. Scarbrough, P.E., Chief  
RCRA and Federal Facilities Branch  
Waste Management Division

ISSUE

The Hazardous and Solid Waste Amendments (HSWA) portion of the RCRA Permit for Safety-Kleen Corporation's facility in Tampa, Florida is attached for your review and signature. This permit requires corrective action for Solid Waste Management Units (SWMUs), notification of newly identified SWMUs, notification of imminent hazards, and annual certification of waste minimization efforts.

BACKGROUND

A draft permit addressing applicable portions of the 1984 HSWA requirements has been public noticed. No comments have been received during the public comment period. The permit will become effective immediately upon issuance as per 40 CFR §124.15.

RECOMMENDATION

I recommend that the Region's final decision be to issue this HSWA permit. The notice of final permit decision and the permit are attached for your signature.

Attachments

UNITED STATES ENVIRONMENTAL PROTECTION  
REGION IV - ATLANTA, GEORGIA

MEMORANDUM

DATE: 007 2 3 1991

SUBJECT: Recommendation for Issuance of HSWA Portion of the  
Resource Conservation and Recovery Act (RCRA) Permit  
for Safety-Kleen Corporation's Tampa Facility  
EPA I.D. Number FLD 980 847 271

FROM: Douglas C. McCurry, Chief *K. Williams*  
Waste Engineering Section *DMC*  
RCRA and Federal Facilities Branch

TO: Donald J. Guinyard, Director  
Waste Management Division

THRU: James H. Scarbrough, P.E., Chief  
RCRA and Federal Facilities Branch  
Waste Management Division

*JHS*  
*12/29/91*

ISSUE

The Hazardous and Solid Waste Amendments (HSWA) portion of the RCRA Permit for Safety-Kleen Corporation's facility in Tampa, Florida is attached for your review and signature. This permit requires corrective action for Solid Waste Management Units (SWMUs), notification of newly identified SWMUs, notification of imminent hazards, and annual certification of waste minimization efforts.

BACKGROUND

A draft permit addressing applicable portions of the 1984 HSWA requirements has been public noticed. No comments have been received during the public comment period. The permit will become effective immediately upon issuance as per 40 CFR §124.15.

RECOMMENDATION

I recommend that the Region's final decision be to issue this HSWA permit. The notice of final permit decision and the permit are attached for your signature.

Attachments



UNITED STATES ENVIRONMENTAL PROTECTION AGENCY

REGION IV

345 COURTLAND STREET, N.E.  
ATLANTA, GEORGIA 30365

OCT 30 1991

4WD-RCRAFFB

CERTIFIED MAIL  
RETURN RECEIPT REQUESTED

Ms. Ellen Jurczak  
Environmental Permits Manager  
Safety-Kleen Corporation  
777 Big Timber Road  
Elgin, Illinois 60123

RE: Decision to Issue HSWA Portion of RCRA Permit  
Safety-Kleen Corporation's Tampa, Florida Facility  
EPA I.D. No. FLD 980 847 271

Dear Ms. Jurczak:

This is notification of the United States Environmental Protection Agency's (EPA) decision to issue the corrective action portion of the Resource Conservation and Recovery Act (RCRA) permit. The enclosed permit covers the requirements of the 1984 Hazardous and Solid Waste Amendments (HSWA). This portion, together with the hazardous waste permit issued by the State of Florida, constitutes a full RCRA permit for Safety-Kleen Corporation's facility in Tampa, Florida.

The final HSWA permit contains no changes from the tentative determination previously public noticed on September 9, 1991. No comments were received during the public comment period. Issuance of this permit is in accordance with 40 CFR Section 124.15. The permit will become effective immediately upon issuance. A summary of the procedures to request an administrative review is enclosed.

The applicable RCRA regulations in effect at the time of permit issuance and referenced in the permit shall be complied with throughout the life of the permit, unless the Permittee requests a modification in accordance with 40 CFR §270.41 and 270.42 or unless the Regional Administrator modifies the permit for newly promulgated regulations (such newly-promulgated regulations may be automatically applicable to all existing permits without the requirement for formal permit modification).

If there are any questions concerning the permit or the appeal procedures, please contact Ms. Susan Zazzali at (404) 347-3433.

Sincerely yours,

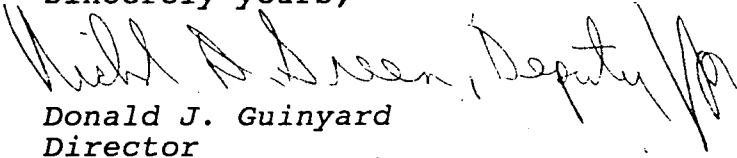

Donald J. Guinyard  
Director  
Waste Management Division

Enclosures: Final HSWA Portion of the RCRA Permit  
Summary of Requirements for Notice of Appeal/  
Petition for Review

cc: Satish Kastury, FDER, Tallahassee (w/enclosure)  
Bill Crawford, FDER, Tampa (w/enclosure)



HSWA PORTION OF THE RCRA PERM.

OWNER/OPERATOR:

Safety Kleen Corporation  
Tampa, Florida Facility  
777 Big Timber Road  
Eglin, Illinois 60123

Identification Number FLD 980 847 271  
Permit Number FLD 980 847 271

Pursuant to the Solid Waste Disposal Act, as amended by the Resource Conservation and Recovery Act of 1976, as amended (42 USC §6901 et seq., commonly known as RCRA) and regulations promulgated thereunder by the U.S. Environmental Protection Agency (EPA) (codified and to be codified in Title 40 of the Code of Federal Regulations), a permit is issued to Safety Kleen Corporation (hereafter called the Permittee), who owns and operates a hazardous waste facility located in Tampa, Florida latitude 27°55'21" North and longitude 82°23'40" West.

This Permit, in conjunction with the Hazardous Waste Management Permit issued by the State of Florida, constitutes the RCRA permit for this facility. The Permittee, pursuant to this permit, shall be required to investigate any releases of hazardous waste or hazardous constituents (from any unit) at the facility regardless of the time at which waste was placed in such unit, and to take corrective action for any such releases on-site and/or off-site. The Permit also requires the Permittee to comply with all land disposal restrictions applicable to this facility and to certify annually that on-site generation of hazardous waste is minimized to the extent practicable.

The Permittee must comply with all terms and conditions of this permit. This permit consists of the conditions contained herein (including those in any attachments) and applicable regulations contained in 40 CFR Parts 260 through 264, 266, 268, 270, and 124 as specified in the permit and statutory requirements of RCRA, as amended by the Hazardous and Solid Waste Amendments (HSWA) of 1984, P.L. 98-616. Nothing in this permit shall preclude the Regional Administrator from reviewing and modifying the permit at any time during its term in accordance with 40 CFR §270.41 and Appendix E, as contained herein.

This Permit is based on the assumption that information and reports submitted to date, and subsequent to issuance of this permit, by the Permittee are accurate. Any inaccuracies found in this information may be grounds for termination or modification of this permit in accordance with 40 CFR §270.41, §270.42, and §270.43 and potential enforcement action. The Permittee must inform EPA of any deviation from or changes in the information in the application which would affect the Permittee's ability to comply with the applicable regulations or permit conditions.

The authority to perform all actions necessary to issue, modify, enforce, or revoke this permit has been delegated by the Regional Administrator to the Waste Management Division Director.

October 30, 1991

October 30, 2001

This Permit is effective as of \_\_\_\_\_, and shall remain in effect until \_\_\_\_\_, unless revoked and reissued, or terminated under 40 CFR §270.41 and §270.43 or continued in accordance with 40 CFR §270.51(a). All obligations for performance of Corrective Action are in effect until deemed complete by the Regional Administrator.

If any conditions of this permit are appealed in accordance with 40 CFR §124.19, the effective date of the conditions determined to be stayed in accordance with 40 CFR §124.16 shall be determined by final agency action as specified under 40 CFR §124.19.

30 Oct 91  
Issued Date

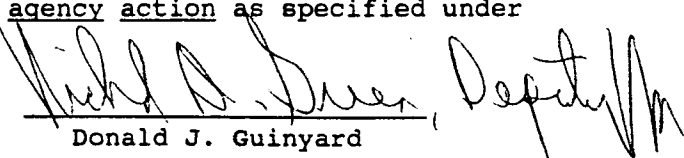
  
Donald J. Guinyard  
Director  
Waste Management Division

BLE OF CONTENTS

	<u>40 CFR Regulatory Citation</u>	<u>Page</u>
Part I STANDARD CONDITIONS		4
I.A. Effect of Permit	\$270.4 \$270.30(g)	4
I.B. Permit Actions	\$270.30(f) \$270.41 \$270.42 \$270.43 \$3005(c) of RCRA	4
I.C. Severability	\$124.16	4
I.D. Duties and Requirements		4
I.D.1. Duty to Comply	\$270.30(a)	5
I.D.2. Duty to Reapply	\$270.10(h) \$270.30(b)	5
I.D.3. Obligation for Corrective Action	\$3004(u) of RCRA \$3004(v) of RCRA	5
I.D.4. Need to Halt or Reduce Activity	\$270.30(c)	5
I.D.5. Duty to Mitigate	\$270.30(d)	5
I.D.6. Proper Operation and Maintenance	\$270.30(e)	5
I.D.7. Duty to Provide Information	\$264.74(a) \$270.30(h)	6
I.D.8. Inspection and Entry	\$270.30(i)	6
I.D.9. Monitoring and Records	\$264.74(b) \$270.30(j)	6
I.D.10. Reporting Planned Changes	\$270.30(l)(1)&(2)	8
I.D.11. Anticipated Noncompliance	\$270.30(l)(2)	8
I.D.12. Transfer of Permit	\$264.12(c) \$270.30(l)(3) \$270.40	8

	<u>40 CFR Regulatory Citation</u>	<u>Page</u>
I.D.13.	Compliance Schedules	§270.33 8
I.D.14.	Twenty-four Hour Reporting	§264.56(d) & (j) §270.30(1)(6) 8
I.D.15.	Other Noncompliance	§270.30(1)(10) 10
I.D.16.	Other Information	§270.30(1)(11) 10
I.E.	Signatory Requirement	§270.11 §270.30(k) 10
I.F.	Confidential Information	§270.12 Part 2 10
I.G.	Definitions	Part 124 Part 260 Part 261 Part 264 Part 270 RCRA HSWA 1984 10
Cover	Permit Authority	Part 124 i
Page	Permit Duration	Part 260 Part 261 Part 264 Part 266 Part 268 Part 270
Part II	CORRECTIVE ACTION	12
II.A.	Applicability	§264.101(a) §270.32(b)(2) Section 3005(c) 12
II.B.	Notification and Assessment for Newly Identified SWMUs and AOCs	§270.14(d) §270.32(c) Section 3005(c) 12
II.C.	Notification Requirements for Newly Discovered Releases at SWMUs	§270.14(d) §270.32(b)(2) & (c) Section 3005(c) 13
II.D.	Confirmatory Sampling	§270.14(d) 14
II.E.	RCRA Facility Investigation	§264.101 15
II.F.	Interim Measures	§264.101 17

	<u>40 CFR Regulatory Citation</u>	<u>Page</u>
II.G.	Corrective Measures Study	§264.101 19
II.H.	Remedy Approval and Permit Modification	§270.41 §270.42 21
II.I.	Modification of Schedule of Compliance	§264.101(b) 21
II.J.	Imminent Hazard	§270.30(e) 21
II.K.	Plan and Report Requirements	§270.11 §270.30(k) 22
Part III	WASTE MINIMIZATION	§264.73(b)(9) 23
Part IV	LAND DISPOSAL RESTRICTIONS	Part 268 23
Part V	AIR EMISSION REQUIREMENTS	Part 264 Subpart AA Subpart BB 25
Part VI	TOXICITY CHARACTERISTIC WASTES	Part 261 28
APPENDIX A	Summary of Solid Waste Management Units and Areas of Concern	A-1
APPENDIX B	RCRA Facility Investigation (RFI) Workplan Outline	B-1
APPENDIX C	Corrective Measures Study (CMS) Plan Outline	C-1
APPENDIX D	Schedule of Compliance	D-1
APPENDIX E	Modification of the Corrective Action Schedule of Compliance	E-1
APPENDIX F	Waste Minimization Certification Requirements	F-1

I.A. EFFECT OF PERMIT

Compliance with this RCRA permit constitutes compliance, for purposes of enforcement, with Subtitle C of RCRA except for those requirements not included in the permit which become effective by statute, which are promulgated, or those which restrict placement of hazardous waste in or on the land. Issuance of this permit does not convey property rights of any sort or any exclusive privilege; nor does it authorize any injury to persons or property, any invasion of other private rights, or any infringement of state or local law or regulations. Compliance with the terms of this permit does not constitute a defense to any order issued or any action brought under Section 3008(a), 3008(h), 3004(v), 3008(c), 3007, 3013 or Section 7003 of RCRA, Sections 104, 106(a), 106(e), or 107 of the Comprehensive Environmental Response, Compensation, and Liability Act of 1980 (42 U.S.C. 9601 et seq., commonly known as CERCLA), or any other law providing for protection of public health or the environment.

I.B. PERMIT ACTIONS

This permit may be modified, revoked and reissued, or terminated for cause as specified in 40 CFR §§270.41, 270.42, and 270.43 except for the Corrective Action schedule of compliance which shall be modified in accordance with Condition II.I. of this permit. The filing of a request for a permit modification, revocation and reissuance, or termination, or the notification of planned changes or anticipated noncompliance on the part of the Permittee does not stay the applicability or enforceability of any permit condition.

I.C. SEVERABILITY

The provisions of this permit are severable, as specified in 40 CFR §124.16 and if any provision of this permit or the application of any provision of this permit to any circumstance is held invalid, the application of such provision to other circumstances and the remainder of this permit shall not be affected thereby.

I.D. DUTIES AND REQUIREMENTS

I.D.1. Duty to Comply

The Permittee shall comply with all conditions of this permit, except to the extent and for the duration such noncompliance is authorized by an emergency permit. Any permit noncompliance, other than noncompliance authorized by an emergency permit, constitutes a violation of RCRA and is grounds for enforcement action, permit termination, revocation and reissuance, modification, or denial of a permit renewal application.

I.D.2. Duty to Reapply

If the Permittee will continue an activity allowed or required by this permit after the expiration date of this permit, the Permittee shall submit a complete application for a new permit at least one hundred eighty (180) calendar days before this permit expires, unless permission for a later date has been granted by the Regional Administrator.

I.D.3. Obligation for Corrective Action

Owners and operators of hazardous waste management units must have permits during the active life (including the closure period) of the unit, and for any period necessary to comply with the corrective action requirements (HSWA Section) of this permit.

I.D.4. Need to Halt or Reduce Activity Not a Defense

It shall not be a defense for the Permittee in an enforcement action that it would have been necessary to halt or reduce the permitted activity in order to maintain compliance with the conditions of this permit.

I.D.5. Duty to Mitigate

In the event of noncompliance with the permit, the Permittee shall take all reasonable steps to minimize releases of hazardous waste or hazardous constituents to the environment, and shall carry out such measures as are reasonable to prevent significant adverse effects on human health or the environment.

I.D.6. Proper Operation and Maintenance

The Permittee shall at all times properly operate and maintain all facilities and systems of treatment and control (and related appurtenances) which are installed or used by the Permittee to achieve compliance with the

conditions of th permit. Proper operation and maintenance includes effective performance, adequate funding, adequate operator staffing and training, and adequate laboratory and process controls, including appropriate quality assurance procedures. This provision requires the operation of backup or auxiliary facilities or similar systems only when necessary to achieve compliance with the conditions of the permit.

I.D.7. Duty to Provide Information

The Permittee shall furnish to the Regional Administrator, within a reasonable time, any relevant information which the Regional Administrator may request to determine whether cause exists for modifying, revoking and reissuing, or terminating this permit, or to determine compliance with this permit. The Permittee shall also furnish to the Regional Administrator, upon request, copies of records required to be kept by this permit.

I.D.8. Inspection and Entry

The Permittee shall allow the Regional Administrator, or an authorized representative, upon the presentation of credentials and other documents as may be required by law to:

I.D.8.a. Enter at reasonable times upon the Permittee's premises where a regulated activity is located or conducted, or where records must be kept under the conditions of this permit;

I.D.8.b. Have access to and copy, at reasonable times, any records that must be kept under the conditions of this permit;

I.D.8.c. Inspect at reasonable times any facilities, equipment (including monitoring and control equipment), practices, or operations regulated, or required under this permit; and

I.D.8.d. Sample or monitor at reasonable times, for the purposes of assuring permit compliance or as otherwise authorized by RCRA, any substances or parameters at any location.

I.D.9. Monitoring and Records

I.D.9.a. Samples and measurements taken for the purpose of monitoring shall be representative of the monitored

activity. The method used to obtain a representative sample to be analyzed must be the appropriate method from Appendix I of 40 CFR Part 261 or an equivalent method approved by the Regional Administrator. Laboratory methods must be those specified in the most recent edition of Test Methods for Evaluating Solid Waste: Physical/Chemical Methods, SW-846, or an equivalent method approved by the Regional Administrator.

I.D.9.b. The Permittee shall retain at the facility, or other appropriate location as provided for under 40 CFR Part 264, records of all monitoring information required under the terms of this permit, including all calibration and maintenance records, records of all data used to prepare documents required by this permit, copies of all reports and records required by this permit, the certification required by 40 CFR §264.73(b)(9), and records of all data used to complete the application for this permit for a period of at least three years from the date of the sample, measurement, report, certification or application, or until corrective action is completed, whichever date is later. As a generator of hazardous waste, the Permittee shall retain on-site a copy of all notices, certifications, demonstrations, waste analysis data, and other documentation produced pursuant to 40 CFR Part 268 for at least five years from the date that the waste which is the subject of such documentation was last sent to on-site or off-site treatment, storage, or disposal, or until corrective action is completed, whichever date is later. At a facility permitted to operate an incinerator, the permittee shall retain on-site all records for a period of five years. These periods may be extended by request of the Regional Administrator at any time and are automatically extended during the course of any unresolved enforcement action regarding this facility.

I.D.9.c. Records of monitoring information shall specify:

- i. The dates, exact place, and times of sampling, or measurements;
- ii. The individuals who performed the sampling or measurements;
- iii. The dates analyses were performed;
- iv. The individuals who performed the analyses;
- v. The analytical techniques or methods used; and



vi. The results of such analyses.

I.D.10. Reporting Planned Changes

The Permittee shall give notice to the Regional Administrator as soon as possible of any planned physical alterations or additions to the permitted facility as defined in 40 CFR §270.2. This would apply to all contiguous land, structures, other appurtenances and improvements on the land, used for the treatment, storage or disposal of hazardous waste.

I.D.11. Anticipated Noncompliance

The Permittee shall give advance notice to the Regional Administrator of any planned changes in the permitted facility or activity which may result in noncompliance with the requirements of this permit.

I.D.12. Transfer of Permits

This permit may be transferred to a new owner or operator only after notice to the Regional Administrator and only if it is modified or revoked and reissued pursuant to 40 CFR §270.40(b) or §270.41(b)(2) to identify the new permittee and incorporate such other requirements as may be necessary under the appropriate Act. Before transferring ownership or operation of the facility during its operating life, or of a disposal facility during the post-closure care period, the Permittee shall notify the new owner or operator in writing of the requirements of 40 CFR Parts 264 and 270, HSWA and this permit.

I.D.13. Compliance Schedules

Written notification of compliance or noncompliance with any item identified in the compliance schedule of this permit shall be submitted according to each schedule date. If the Permittee does not notify the Regional Administrator within fourteen (14) calendar days of its compliance or noncompliance with the schedule, the Permittee shall be subject to an enforcement action. Submittal of a required item according to the schedule constitutes notification of compliance.

I.D.14. Twenty-four Hour Reporting

I.D.14.a. The Permittee shall report any noncompliance which may endanger human health or the environment. Any such

information shall be reported orally to the Regional Administrator within 24 hours from the time the Permittee becomes aware of the circumstances. This report shall include:

- i. Information concerning the release of any hazardous waste or hazardous constituents which may endanger public drinking water supplies.
- ii. Information concerning the release or discharge of any hazardous waste or hazardous constituents, or of a fire or explosion at the facility, which could threaten the environment or human health outside the facility.

I.D.14.b. The description of the occurrence and its cause shall include:

- i. Name, address, and telephone number of the owner or operator;
- ii. Name, address, and telephone number of the facility;
- iii. Date, time, and type of incident;
- iv. Name and quantity of materials involved;
- v. The extent of injuries, if any;
- vi. An assessment of actual or potential hazard to the environment and human health outside the facility; and
- vii. Estimated quantity and disposition of recovered material that resulted from the incident.

I.D.14.c. A written report shall also be provided to the Regional Administrator within fifteen (15) calendar days of the time the Permittee becomes aware of the circumstances. The written report shall contain the information specified under Conditions I.D.14.a. and b.; a description of the noncompliance and its cause; the periods of noncompliance (including exact dates and times); whether the noncompliance has been corrected; and if not, the anticipated time it is expected to continue; and steps taken or planned to reduce, eliminate, and prevent recurrence of the noncompliance.

I.D.15. Other Noncompliance

The Permittee shall report all other instances of noncompliance not otherwise required to be reported above, at the time written reports as required by this permit are submitted. The reports shall contain the information listed in Condition I.D.14. as appropriate.

I.D.16. Other Information

Whenever the Permittee becomes aware that it failed to submit any relevant facts or submitted incorrect information in any document(s) submitted to the Regional Administrator, the Permittee shall promptly submit such facts or information.

I.E. SIGNATORY REQUIREMENT

All applications, reports, or information submitted to the Regional Administrator shall be signed and certified in accordance with 40 CFR §270.11.

I.F. CONFIDENTIAL INFORMATION

The Permittee may claim confidential any information required to be submitted by this permit in accordance with 40 CFR §270.12.

I.G. DEFINITIONS

For purposes of this permit, terms used herein shall have the same meaning as those in RCRA and 40 CFR Parts 124, 260, 261, 264, and 270, unless this permit specifically provides otherwise. Where terms are not defined in the regulation, the permit, or EPA guidelines or publications, the meaning associated with such terms shall be defined by a standard dictionary reference or the generally accepted scientific or industrial meaning of the term.

I.G.1. The term "solid waste" means any garbage, refuse, sludge from a waste treatment plant, water supply treatment plant, or air pollution control facility and other discarded material, including solid, liquid, semisolid, or contained gaseous material resulting from industrial, commercial, mining, and agricultural operations, and from community activities, but does not include solid or dissolved material in domestic sewage, or solid or dissolved materials in irrigation return flows or

industrial discharges which are point sources subject to permits under section 402 of the Federal Water Pollution Control Act, as amended (86 Stat. 880), or source, special nuclear, or by-product material as defined by the Atomic Energy Act of 1954, as amended (68 Stat. 923).

- I.G.2. A "hazardous constituent" for purposes of this permit are those substances listed in 40 CFR Part 261 Appendix VIII.
- I.G.3. A "solid waste management unit" (SWMU) for the purposes of this permit includes any unit which has been used for the treatment, storage, or disposal of solid waste at any time, irrespective of whether the unit is or ever was intended for the management of solid waste. RCRA regulated hazardous waste management units are also solid waste management units. SWMUs include areas that have been contaminated by routine and systematic releases of hazardous waste or hazardous constituents, excluding one-time accidental spills that are immediately remediated and cannot be linked to solid waste management activities (e.g. product or process spills).
- I.G.4. A "unit" for the purposes of this permit includes, but is not limited to, any landfill, surface impoundment, waste pile, land treatment unit, incinerator, injection well, tank, container storage area, septic tank, drain field, wastewater treatment unit, elementary neutralization unit, transfer station, or recycling unit.
- I.G.5. A "release" for purposes of this permit includes any spilling, leaking, pumping, pouring, emitting, emptying, discharging, injecting, escaping, leaching, dumping, or disposing into the environment of any hazardous waste or hazardous constituents.
- I.G.6. "Corrective measures" for purposes of this permit, include all corrective action necessary to protect human health and the environment for all releases of hazardous waste or hazardous constituents from any solid waste management unit at the facility, regardless of the time at which waste was placed in the unit, as required under 40 CFR §264.101. Corrective measures may address releases to air, soils, surface water or groundwater.
- I.G.7. "Area of concern" (AOC) for purposes of this permit includes any area having a probable release of a hazardous waste or hazardous constituent which is not from a solid waste management unit and is determined by the Regional Administrator to pose a current or potential threat to human health or the environment. Such areas of concern may

require investigations and remedial action as required under Section 3005(c)(3) of the Resource Conservation and Recovery Act and 40 CFR §270.32(b)(2) in order to ensure adequate protection of human health and the environment.

- I.G.8. "Facility" for purposes of this permit includes any contiguous property and structures, other appurtenances, and improvements on the property under the control of the owner or operator seeking a permit under subtitle C of RCRA.
- I.G.9. "Land Disposal" for purposes of this permit and 40 CFR Part 268 means placement in or on the land and includes, but is not limited to, placement in a landfill, surface impoundment, waste pile, injection well, land treatment facility, salt dome formation, underground mine or cave, or concrete vault or bunker intended for disposal purposes.

## PART II - CORRECTIVE ACTION

### II.A. APPLICABILITY

The Conditions of this Part apply to:

- II.A.1. The solid waste management units (SWMUs) identified in Appendix A-1, which require further investigation.
- II.A.2. The SWMUs identified in Appendix A-2, which require no further investigation at this time.
- II.A.3. The SWMUs identified in Appendix A-3, which require confirmatory sampling.
- II.A.4. Any additional SWMUs or areas of concern (AOCs) discovered during the course of groundwater monitoring, field investigations, environmental audits, or other means.

### II.B. NOTIFICATION AND ASSESSMENT REQUIREMENTS FOR NEWLY IDENTIFIED SWMUS AND AOCs

- II.B.1. The Permittee shall notify the Regional Administrator in writing, within fifteen (15) calendar days of discovery, of any additional SWMUs as discovered under Condition II.A.4.
- II.B.2. The Permittee shall notify the Regional Administrator in writing, within fifteen (15) calendar days of discovery, of any additional AOCs as discovered under Condition II.A.4. The notification shall include, at a minimum, the location

of the AOC and a available information pertaini to the nature of the release (e.g., media affected, hazardous constituents released, magnitude of release, etc.). If the Regional Administrator determines that further investigation of an AOC is required, the permit will be modified in accordance with 40 CFR §270.41.

- II.B.3. The Permittee shall prepare and submit to the Regional Administrator, within ninety (90) calendar days of notification, a SWMU Assessment Report (SAR) for each SWMU identified under Condition II.B.1. At a minimum, the SAR shall provide the following information:
- a. Location of unit(s) on a topographic map of appropriate scale such as required under 40 CFR §270.14(b)(19).
  - b. Designation of type and function of unit(s).
  - c. General dimensions, capacities and structural description of unit(s) (supply any available plans/drawings).
  - d. Dates that the unit(s) was operated.
  - e. Specification of all wastes that have been managed at/in the unit(s) to the extent available. Include any available data on 40 CFR Part 261, Appendix VIII, constituents in the wastes.
  - f. All available information pertaining to any release of hazardous waste or hazardous constituents from such unit(s) (to include groundwater data, soil analyses, air, and/or surface water data).

II.B.4. Based on the results of the SAR, the Regional Administrator shall determine the need for further investigations at the SWMUs covered in the SAR. If the Regional Administrator determines that such investigations are needed, the Permittee shall be required to prepare a plan for such investigations as outlined in Condition II.E.1.b.

II.C. NOTIFICATION REQUIREMENTS FOR NEWLY DISCOVERED RELEASES AT PREVIOUSLY IDENTIFIED SWMUs

II.C.1. The Permittee shall notify the Regional Administrator in writing of any newly discovered release(s) of hazardous waste or hazardous constituents discovered during the course of groundwater monitoring, field investigations, environmental audits, or other means, within fifteen (15) calendar days of discovery. Such newly discovered releases

may be from SWMU identified in Conditions II.A.2 I.A.3 or SWMUs identified in Condition II.A.4 for which further investigation under Condition II.B.4 was not required.

II.C.2. If the Regional Administrator determines that further investigation of the SWMUs is needed, the Permittee shall be required to prepare a plan for such investigations as outlined in Condition II.E.1.b.

II.D. CONFIRMATORY SAMPLING (CS)

II.D.1. The Permittee shall prepare and submit to the Regional Administrator, within sixty (60) calendar days of the effective date of this permit, a Confirmatory Sampling (CS) Workplan to determine any release from SWMUs identified in Condition II.A.3 and Appendix A-3. The CS Workplan shall include schedules of implementation and completion of specific actions necessary to determine a release. It should also address applicable requirements and affected media. Completion of all Confirmatory Sampling shall not exceed sixty (60) days.

II.D.2. The CS Workplan must be approved by the Regional Administrator, in writing, prior to implementation. The Regional Administrator shall specify the start date of the CS Workplan schedule in the letter approving the CS Workplan. If the Regional Administrator disapproves the CS Workplan, the Regional Administrator shall either (1) notify the Permittee in writing of the CS Workplan's deficiencies and specify a due date for submission of a revised CS Workplan, or (2) revise the CS Workplan and notify the Permittee of the revisions.

II.D.3. The Permittee shall implement the confirmatory sampling in accordance with the approved CS Workplan.

II.D.4. The Permittee shall prepare and submit to the Regional Administrator in accordance with the approved schedule, a Confirmatory Sampling (CS) Report identifying those SWMUs listed in Condition II.A.3 that have released hazardous waste or hazardous constituents into the environment. The CS Report shall include all data, including raw data, and a summary and analysis of the data, that supports the above determination.

II.D.5. Based on the results of the CS Report, the Regional Administrator shall determine the need for further investigations of the SWMUs covered in the CS Report. If the Regional Administrator determines that such investigations are needed, the Permittee shall be required

to prepare a plan or such investigations as outlined in Condition II.E.1.b. The Regional Administrator will notify the permittee of any no further action decision.

II.E. RCRA FACILITY INVESTIGATION (RFI)

II.E.1. RFI Workplan(s)

- II.E.1.a. The Permittee shall prepare and submit to the Regional Administrator, within one hundred twenty (120) calendar days of notification by the Regional Administrator a RCRA Facility Investigation (RFI) Workplan(s) for those units identified in Condition II.A.1. This Workplan shall be developed to meet the requirements of Condition II.E.1.c.
- II.E.1.b. The Permittee shall prepare and submit to the Regional Administrator, within ninety (90) calendar days of notification by the Regional Administrator, an RFI Workplan for those units identified under Condition II.B.4, Condition II.C.2, or Condition II.D.5. The RFI Workplan(s) shall be developed to meet the requirements of Condition II.E.1.c.
- II.E.1.c. The RFI Workplan(s) shall meet the requirements of Appendix B. The RFI Workplan(s) shall include schedules of implementation and completion of specific actions necessary to determine the nature and extent of releases and the potential pathways of contaminant releases to the air, land, surface water, and groundwater. In addition, the Permittee shall include the above schedules for specific actions beyond facility boundary, where necessary to protect human health and the environment. The Permittee must provide sufficient justification and/or documentation that a release is not probable if a unit or a media/pathway associated with a unit (groundwater, surface water, soil, subsurface gas, or air) is not included in the RFI Workplan(s). Such deletions of a unit, media or pathway from the RFI(s) are subject to the approval of the Regional Administrator. The Permittee shall provide sufficient written justification for any omissions or deviations from the minimum requirements of Appendix B. Such omissions or deviations are subject to the approval of the Regional Administrator. In addition, the scope of the RFI Workplan(s) shall include all investigations necessary to ensure compliance with 40 CFR §264.101(c).
- II.E.1.d. The RFI Workplan(s) must be approved by the Regional Administrator, in writing, prior to implementation. The Regional Administrator shall specify the start date of the RFI Workplan schedule in the letter approving the RFI Workplan(s). If the Regional Administrator disapproves the RFI Workplan(s), the Regional Administrator shall either (1) notify the Permittee in writing of the RFI Workplan's



deficiencies and specify a due date for submission of a revised RFI Workplan, or (2) revise the RFI Workplan and notify the Permittee of the revisions and the start date of the schedule within the approved RFI Workplan.

II.E.2. RFI Implementation

The Permittee shall implement the RFI(s) in accordance with the approved RFI Workplan(s) and Appendix B. The Permittee shall notify the Regional Administrator within twenty (20) days of any sampling activity.

II.E.3. RFI Reports

II.E.3.a. If the time required to conduct the RFI(s) is greater than one hundred eighty (180) calendar days, the Permittee shall provide the Regional Administrator with quarterly RFI Progress Reports (90 day intervals) beginning ninety (90) calendar days from the start date specified by the Regional Administrator in the RFI Workplan approval letter. The Progress Reports shall contain the following information at a minimum:

- i. A description of the portion of the RFI completed;
- ii. Summaries of findings;
- iii. Summaries of all deviations from the approved RFI Workplan during the reporting period;
- iv. Summaries of all problems or potential problems encountered during the reporting period;
- v. Projected work for the next reporting period; and
- vi. Copies of daily reports, inspection reports, laboratory/monitoring data, etc.

II.E.3.b. The Permittee shall prepare and submit to the Regional Administrator Draft and Final RCRA Facility Investigation Report(s) for the investigations conducted pursuant to the RFI Workplan(s) submitted under Condition II.E.1. The Draft RFI Report(s) shall be submitted to Regional Administrator for review in accordance with the schedule in the approved RFI Workplan(s). The Final RFI Report(s) shall be submitted to the Regional Administrator within thirty (30) calendar days of receipt of the Regional Administrator's comments on the Draft RFI Report. The RFI Report(s) shall include an analysis and summary of all required investigations of SWMUs and their results. The

summary shall describe the type and extent of contamination at the facility, including sources and migration pathways, and a description of actual or potential receptors. The RFI Report(s) shall also describe the extent of contamination (qualitative/quantitative) in relation to background levels indicative of the area. The objective of this task shall be to ensure that the investigation data are sufficient in quality (e.g., quality assurance procedures have been followed) and quantity to describe the nature and extent of contamination, potential threat to human health and/or the environment, and to support a Corrective Measures Study, if necessary.

II.E.3.c. The Regional Administrator will review the Final RFI Report(s) and notify the Permittee of the need for further investigative action and/or the need for a Corrective Measures Study to meet the requirements of II.G and 40 CFR §264.101. The RA will notify the permittee of any no further action decision.

II.F. INTERIM MEASURES (IM)

II.F.1. IM Workplan

II.F.1.a. Upon notification by the Regional Administrator, the Permittee shall prepare and submit an Interim Measures (IM) Workplan for any SWMU which the Regional Administrator determines poses a current or potential threat to human health or the environment. The IM Workplan shall be submitted within thirty (30) calendar days of such notification and shall include the elements listed in II.F.1.b. Such interim measures may be conducted concurrently with investigations required under the terms of this permit.

II.F.1.b. The IM Workplan shall ensure that the interim measures are designed to mitigate any current or potential threat(s) to human health or the environment and are consistent with and integrated into any long-term solution at the facility. The IM Workplan shall include: the interim measures objectives, procedures for implementation (including any designs, plans, or specifications), and schedules for implementation.

II.F.1.c. The IM Workplan must be approved by the Regional Administrator, in writing, prior to implementation. The Regional Administrator shall specify the start date of the IM Workplan schedule in the letter approving the IM Workplan. If the Regional Administrator disapproves the IM Workplan, the Regional Administrator shall either (1)

notify the Permittee in writing of the IM Workplan deficiencies and specify a due date for submission of a revised IM Workplan, or (2) revise the IM Workplan and notify the Permittee of the revisions and the start date of the schedule within the approved IM Workplan.

II.F.2. IM Implementation

II.F.2.a. The Permittee shall implement the interim measures in accordance with the approved IM Workplan.

II.F.2.b. The Permittee shall give notice to the Regional Administrator as soon as possible of any planned changes, reductions or additions to the IM Workplan.

II.F.2.c. Final approval of corrective action required under 40 CFR §264.101 which is achieved through interim measures shall be in accordance with 40 CFR §270.41 and Condition II.H as a permit modification.

II.F.3. IM Reports

II.F.3.a. If the time required for completion of interim measures is greater than one year, the Permittee shall provide the RA with monthly progress reports (30 day intervals) beginning 30 calendar days from the start date specified by the Regional Administrator in the Workplan approval letter. The Progress Reports shall contain the following information at a minimum:

- i. A description of the portion of the interim measures completed;
- ii. Summaries of all deviations from the IM Workplan during the reporting period;
- iii. Summaries of all problems or potential problems encountered during the reporting period;
- iv. Projected work for the next reporting period; and
- v. Copies of laboratory/monitoring data.

II.F.3.b. The Permittee shall prepare and submit to the Regional Administrator, within ninety (90) calendar days of completion of interim measures conducted under Condition II.F, an Interim Measures (IM) Report. The IM Report shall contain the following information at a minimum:

- i. A description of interim measures implemented;

- ii. Summaries results;
- iii. Summaries of all problems encountered;
- iv. Summaries of accomplishments and/or effectiveness of interim measures; and
- v. Copies of all relevant laboratory/monitoring data, etc. in accordance with Condition I.D.9.

II.G CORRECTIVE MEASURES STUDY

II.G.1. Corrective Measures Study (CMS) Plan

II.G.1.a. The Permittee shall prepare and submit a CMS Plan for those units requiring a CMS within ninety (90) calendar days of notification by the Regional Administrator that a CMS is required. This CMS Plan shall be developed to meet the requirements of Condition II.G.1.b.

II.G.1.b. The CMS Plan shall meet the requirements of Appendix C. The CMS Plan shall include schedules of implementation and completion of specific actions necessary to complete a CMS. The Permittee must provide sufficient justification and/or documentation for any unit deleted from the CMS Plan. Such deletion of a unit is subject to the approval of the Regional Administrator. The CMS shall be conducted in accordance with the approved CMS Plan. The Permittee shall provide sufficient written justification for any omissions or deviations from the minimum requirements of Appendix C. Such omissions or deviations are subject to the approval of the Regional Administrator. The scope of the CMS Plan shall include all investigations necessary to ensure compliance with 3005(c)(3), 3004(v), 40 CFR §264.101, and §270.32(b)(3). The Permittee shall implement corrective actions beyond the facility boundary, where necessary to protect human health and the environment, unless the Permittee demonstrates to the satisfaction of the Regional Administrator that, despite the Permittee's best efforts, as determined by the RA, the Permittee was unable to obtain the necessary permission to undertake such actions. The Permittee is not relieved of all responsibility to clean up a release that has migrated beyond the facility boundary where off-site access is denied. On-site measures to address such releases will be determined on a case-by-case basis. Assurances of financial responsibility for completion of such off-site corrective action will be required.

II.G.1.c. The Regional Administrator shall either approve or

disapprove, in writing, the CMS plan. If the Regional Administrator disapproves the CMS Plan, the Regional Administrator shall either (1) notify the Permittee in writing of the CMS Plan's deficiencies and specify a due date for submittal of a revised CMS Plan, or (2) revise the CMS Plan and notify the Permittee of the revisions. This modified CMS Plan becomes the approved CMS Plan.

II.G.2. Corrective Measures Study Implementation

The Permittee shall begin to implement the Corrective Measures Study according to the schedules specified in the CMS Plan, no later than fifteen (15) calendar days after the Permittee has received written approval from the Regional Administrator for the CMS Plan. Pursuant to Permit Condition II.G.1.b. the CMS shall be conducted in accordance with the approved CMS Plan.

II.G.3. CMS Report

II.G.3.a. The Permittee shall prepare and submit to the Regional Administrator a draft and final CMS Report for the study conducted pursuant to the approved CMS Plan. The draft CMS Report shall be submitted to the Regional Administrator within ninety (90) calendar days from the Regional Administrator's approval of the CMS Plan. The final CMS Report shall be submitted to the Regional Administrator within thirty (30) days of receipt of the Regional Administrator's comments on the draft CMS Report. The CMS Report shall summarize any bench-scale or pilot tests conducted. The CMS Report must include an evaluation of each remedial alternative. The CMS Report shall present all information gathered under the approved CMS Plan. The CMS Final Report must contain adequate information to support the Regional Administrator's decision on the recommended remedy, described under Permit Condition II.H.

II.G.3.b. If the Regional Administrator determines that the CMS Final Report does not fully satisfy the information requirements specified under Permit Condition II.G.3.a, the Regional Administrator may disapprove the CMS Final Report. If the Regional Administrator disapproves the CMS Final Report, the Regional Administrator shall notify the Permittee in writing of deficiencies in the CMS Final Report and specify a due date for submittal of a revised CMS Final Report. The Regional Administrator will notify the Permittee of any no further action decision.

II.G.3.c. As specified under Permit Condition II.G.3.b., based on preliminary results and the CMS Final Report, the Regional

Administrator may require the Permittee to evaluate additional remedies or particular elements of one or more proposed remedies.

II.H. REMEDY APPROVAL AND PERMIT MODIFICATION

- II.H.1. A remedy shall be selected from the remedial alternatives evaluated in the CMS. It will be based at a minimum on protection of human health and the environment, as per specific site conditions, existing regulations, and guidance.
- II.H.2. Pursuant to 40 CFR §270.41, a permit modification will be initiated by the Regional Administrator after recommendation of a remedy under Condition II.H.1. This modification will serve to incorporate a final remedy into this permit.
- II.H.3. Within One Hundred and Twenty (120) calendar days after this Permit has been modified, the Permittee shall demonstrate financial assurance for completing the approved remedy.

II.I. MODIFICATION OF THE CORRECTIVE ACTION SCHEDULE OF COMPLIANCE

- II.I.1. If at any time the Regional Administrator determines that modification of the Corrective Action Schedule of Compliance is necessary, the Regional Administrator may initiate a modification to the Schedule of Compliance (Appendix D).
- II.I.2. Modifications that are initiated and finalized by the Regional Administrator according to proper procedure, as outlined in Appendix E, shall not be subject to administrative appeal.
- II.I.3. Modifications to the Schedule of Compliance do not constitute a reissuance of the Permit.

II.J. IMMINENT HAZARDS

- II.J.1. The Permittee shall report to the Regional Administrator any imminent or existing hazard to public health or the environment from any release of hazardous waste or hazardous constituents. Such information shall be reported orally within 24 hours from such time the Permittee becomes aware of the circumstances. This report shall include the information specified under Conditions I.D.14.a. and b.

II.J.2. A written report shall also be provided to the Regional Administrator within fifteen (15) calendar days of the time the Permittee becomes aware of the circumstances. The written report shall contain the information specified under Conditions I.D.14.a. and b.; a description of the release and its cause; the period of the release; whether the release has been stopped; and if not, the anticipated time it is expected to continue; and steps taken or planned to reduce, eliminate, and prevent recurrence of the release.

II.K. PLAN AND REPORT REQUIREMENTS

II.K.1. All plans and schedules shall be subject to approval by the Regional Administrator prior to implementation. The Permittee shall revise all submittals and schedules as specified by the Regional Administrator. Upon approval the Permittee shall implement all plans and schedules as written.

II.K.2. The results of all plans and reports shall be submitted in accordance with the approved schedule. Extensions of the due date for submittals may be granted by the Regional Administrator based on the Permittee's demonstration that sufficient justification for the extension exists.

II.K.3. If the Permittee at any time determines that the SAR information required under Condition II.B., the CS Workplan under II.D., or RFI Workplan(s) required under Condition II.E. no longer satisfy the requirements of 40 CFR §264.101 or this permit for prior or continuing releases of hazardous waste or hazardous constituents from solid waste management units, the Permittee shall submit an amended RFI Workplan(s) to the Regional Administrator within ninety (90) calendar days of such determination.

II.K.4. All reports shall be signed and certified in accordance with 40 CFR §270.11.

II.K.5. Two (2) copies of all reports and plans shall be provided by the Permittee to the Regional Administrator in care of Mr. James H. Scarbrough at the following address:

Mr. James H. Scarbrough, P.E.  
Chief, RCRA and Federal Facilities Branch  
Waste Management Division  
Environmental Protection Agency  
Region IV  
345 Courtland Street  
Atlanta, Georgia 30365

PART II. WASTE MINIMIZATION

- III.A. Pursuant to 40 CFR §264.73(b)(9), and Section 3005(h) of RCRA, 42 U.S.C. 6925(h), the Permittee must certify, no less often than annually, that:
- III.A.1. The Permittee has a program in place to reduce the volume and toxicity of hazardous waste generated to the degree determined by the Permittee to be economically practicable; and
- III.A.2. The proposed method of treatment, storage or disposal is the most practicable method available to the Permittee which minimizes the present and future threat to human health and the environment.
- III.B. The Permittee shall maintain copies of this certification in the facility operating record as required by 40 CFR §264.73(b)(9).
- III.C. The Waste Minimization program required under III.A. above should address the objectives listed in Appendix F.

PART IV - LAND DISPOSAL RESTRICTIONS

IV.A. GENERAL RESTRICTIONS

- IV.A.1. 40 CFR Part 268 identifies hazardous wastes that are restricted from land disposal and defines those limited circumstances which an otherwise prohibited waste may continue to be placed on or in a land treatment, storage or disposal unit. The Permittee shall maintain compliance with the requirements of 40 CFR Part 268. Where the Permittee has applied for an extension, waiver or variance under 40 CFR Part 268, the Permittee shall comply with all restrictions on land disposal under this Part once the effective date for the waste has been reached pending final approval of such application.

IV.B. LAND DISPOSAL PROHIBITIONS AND TREATMENT STANDARDS

- IV.B.1. A restricted waste identified in 40 CFR Part 268 Subpart C may not be placed in a land disposal unit without further treatment unless the requirements of 40 CFR Part 268 Subparts C and/or D are met.



V.B.2. The storage of hazardous wastes restricted from land disposal under 40 CFR Part 268 is prohibited unless the requirements of 40 CFR Part 268 Subpart E are met.

PART V - ORGANIC AIR EMISSION REQUIREMENTS

The Permittee shall comply with the Organic Air Emissions Requirements of 40 CFR 264, Subpart BB for equipment leaks.

V.A. PERMITTED WASTE COMPLIANCE

V.A.1. The Permittee may manage the following wastes with equipment subject to the terms of this Permit as follows:

<u>Equipment ID. Num.</u>	<u>Equipment Type</u>	<u>Hazardous Waste Unit</u>	<u>Description of Hazardous Waste</u>
1	flange	Ancillary	Mineral Spirits
2	valve	Piping	"
3	valve	"	"
4	valve	Tank	"
5	valve	"	"
6	pump	Piping	"
8	valve	"	"
9	pump	"	"
10	valve	"	"
11	valve	"	"
12	valve	"	"
13	flange	"	"
14	valve	"	"
15	pump	"	"
16	valve	"	"
18	valve	"	"
19	flange	"	"
20	valve	"	"
21	valve	"	"
22	flange	"	"
23	valve	"	"

V.B. EMISSION CONTROL TECHNOLOGY

V.B.1. The Permittee shall operate and maintain equipment according to detailed plans contained in Permit Attachment 1.

V.C. MONITORING AND INSPECTION SCHEDULES AND PROCEDURES

V.C.1. VALVES

The following valves shall be considered in heavy liquid service, shall be monitored visually,

audibly, by olfactory methods, or other detection method daily and shall comply with the required repair program if evidence of a leak is found as required by 40 CFR 264.1058.

<u>Valve Identification #</u>	<u>Hazardous Waste Management Unit</u>
2	Piping
3	"
4	Tank
5	"
8	Piping
10	"
11	"
12	"
14	"
16	"
18	"
20	"
21	"
23	"

V.C.2. PUMPS

The following pumps shall be monitored visually, audibly, by olfactory methods, or other detection method daily and comply with the required repair program if evidence of a leak is found as required by 40 CFR 264.1058:

<u>Pump I.D. Number</u>	<u>Hazardous Waste Management Unit</u>
6	Piping
7	"
15	"

V.C.3. FLANGES

The following flanges shall be monitored visually, audibly, by olfactory methods, or other detection method daily and comply with the required repair program if evidence of a leak is found as required by 40 CFR 264.1058:

<u>Flange I.D. Number</u>	<u>Hazardous Waste Management Unit</u>
1	Piping
13	"
19	"
22	"

V.D. RECORD KEEPING AND REPORTING

- V.D.1. The Permittee shall keep on file the following equipment information: listing of an identification number for each piece of equipment that contains or contacts hazardous wastes with organic concentrations of at least ten (10) percent by weight; the respective hazardous waste management unit; each piece of equipment's specific location at the facility; the type of equipment; the hazardous waste state at the equipment; and the method of compliance with the standard as required by 40 CFR §264.1064(b)(1).
- V.D.2. The Permittee shall identify each piece of leaking equipment and provide record keeping as required by 40 CFR §264.1064(d).
- V.D.3. The Permittee shall comply with the recordkeeping requirements for valves which are unsafe or difficult to monitor as required by 40 CFR §264.1064(h).
- V.D.4. The Permittee shall comply with the record keeping requirements for valves monitored under the skip leak repair program as required by 40 CFR §264.1064(i).
- V.D.5. The Permittee shall keep on file all information used in determining exemptions as required by 40 CFR 264.1064(k).
- V.D.6. The Permittee shall report semiannually to the Regional Administrator the information on each valve, pump and/or flange leaks that were not repaired in accordance with requirements, the dates of hazardous waste management unit shut downs as required by 40 CFR §264.1065(a).

PART VI - TOXICITY CHARACTERISTIC WASTES

VI.A Authorized Toxicity Characteristic Waste Codes

D004	D024	D038
D005	D025	D039
D006	D026	D040
D007	D027	D041
D008	D028	D042
D009	D029	D043
D010	D030	
D011	D032	
D018	D033	
D019	D034	
D021	D035	
D022	D036	
D023	D037	

VI.B Waste Analysis Plan

The Permittee must analyze the waste listed under Condition VI.A above utilizing the Toxicity Characteristic Leaching Procedure (TCLP). The TCLP (Method 1311) is specified under 40 CFR 261 Appendix II.

VI.C General Requirements

The Permittee must store and treat the wastes listed under Condition VI.A above in accordance with the conditions of the State operating permit.

APPENDIX A

SOLID WASTE MANAGEMENT UNIT SUMMARY

APPENDIX A-1

SOLID WASTE MANAGEMENT UNITS

<u>SWMU No.</u>	<u>SWMU Description</u>
1.	Service Center Drum Storage Area and Associated Trench
2.	Drummed Dry-Cleaning and Paint Waste Unloading Dock
3.	Solvent Return Wet Dumpsters (3)
4.	Spill Containment Area Below the Fill Shelters
5.	Drum Rinsing Area
6.	Waste Solvent Storage Tank
7.	Stormwater Ditch
8.	Accumulation Center Drum Storage Area and Associated Trench
9.	Drummed Waste Loading Docks (3)
10.	Drummed Flammable Waste Storage Room
11.	Old Dumping Ground
12.	Stormwater Retention Pond

APPENDIX A-2

SOLID WASTE MANAGEMENT UNITS  
REQUIRING NO FURTHER ACTION

<u>SWMU No.</u>	<u>SWMU Description</u>
1	Service Center Drum Storage Area and Associated Trench
2	Drummed Dry-Cleaning and Paint Waste Unloading Dock
3	Solvent Return Wet Dumpsters (3)
4	Spill Containment Area Below the Fill Shelters
5	Drum Rinsing Area
6	Waste Solvent Storage Tank
7	Stormwater Ditch
8	Accumulation Center Drum Storage Area and Associated Trench
9	Drummed Waste Loading Docks (3)
10	Drummed Flammable Waste Storage Room
12	Stormwater Retention Pond



APPENDIX A-3

The Following Solid Waste Management Units require confirmatory sampling:

SWMU Number

11

Old Dumping Ground

APPENDIX B

RCRA Facility Investigation (RFI)  
Workplan Outline

APPENDIX B

RCRA FACILITY INVESTIGATION (RFI) WORKPLAN OUTLINE

I. RFI WORKPLAN REQUIREMENTS

The Permittee shall prepare a RCRA Facility Investigation (RFI) Workplan that meets the requirements of Part II of this document and the RFI Guidance, EPA-530/SW-89-031. This Workplan shall also include the development of the following plans, which shall be prepared concurrently:

A. Project Management Plan

Permittee shall prepare a Project Management Plan which will include a discussion of the technical approach, schedules and personnel. The Project Management Plan will also include a description of qualifications of personnel, performing or directing the RFI, including contractor personnel. This plan shall also document the overall management approach to the RCRA Facility Investigation.

B. Sampling and Analysis Plan(s)

The Permittee shall prepare a plan to document all monitoring procedures: field sampling, sampling procedures and sample analysis performed during the investigation to characterize the environmental setting, source, and releases of hazardous constituents, so as to ensure that all information and data are valid and properly documented. The Sampling Strategy and Procedures shall be in accordance with Characterization of Hazardous Waste Sites A Methods Manual: Volume II., Available Sampling Methods, EPA-600/4-84-076, or EPA Region IV Engineering Support Branch's Standard Operating Procedure and Quality Assurance Manual (SOP). Any deviations from these references must be requested by the applicant and approved by EPA. The Sampling and Analysis Plan must specifically discuss the following unless the EPA-600/4-84-076 or SOP procedures are specifically referenced.

1. Sampling Strategy

- a. Selecting appropriate sampling locations, depths, etc.;
- b. Obtaining all necessary ancillary data;
- c. Determining conditions under which sampling should be conducted;

- d. Determining which media are to be sampled (e.g., groundwater, air, soil, sediment, subsurface gas);
- e. Determining which parameters are to be measured and where;
- f. Selecting the frequency of sampling and length of sampling period;
- g. Selecting the types of samples (e.g., composites vs. grabs) and number of samples to be collected.

2. Sampling Procedures

- a. Documenting field sampling operations and procedures, including;
  - i) Documentation of procedures for preparation of reagents or supplies which become an integral part of the sample (e.g., filters, preservatives, and absorbing reagents);
  - ii) Procedures and forms for recording the exact location and specific considerations associated with sample acquisition;
  - iii) Documentation of specific sample preservation method;
  - iv) Calibration of field instruments;
  - v) Submission of field-biased blanks, where appropriate;
  - vi) Potential interferences present at the facility;
  - vii) Construction materials and techniques, associated with monitoring wells and piezometers;
  - viii) Field equipment listing and sampling containers;
  - ix) Sampling order; and
  - x) Decontamination procedures.
- b. Selecting appropriate sample containers;
- c. Sampling preservation; and

**DRAFT**

d. Chain-of-custody, including:

- i) Standardized field tracking reporting forms to establish sample custody in the field prior to shipment; and
- ii) Pre-prepared sample labels containing all information necessary for effective sample tracking.

3. Sample Analysis

Sample analysis shall be conducted in accordance with SW-846: "Test Methods for Evaluating Solid Waste - Physical/Chemical Methods" (third edition). The sample analysis section of the Sampling and Analysis Plan shall specify the following:

a. Chain-of-custody procedures, including:

- i) Identification of a responsible party to act as sampling custodian at the laboratory facility authorized to sign for incoming field samples, obtain documents of shipment, and verify the data entered onto the sample custody records;
- ii) Provision for a laboratory sample custody log consisting of serially numbered standard lab-tracking report sheets; and
- iii) Specification of laboratory sample custody procedures for sample handling, storage, and dispersment for analysis.

b. Sample storage;

c. Sample preparation methods;

d. Analytical Procedures, including:

- i) Scope and application of the procedure;
- ii) Sample matrix;
- iii) Potential interferences;
- iv) Precision and accuracy of the methodology; and
- v) Method detection limits.

e. Calibration procedures and frequency;

f. Data reduction, validation and reporting;

**DRAFT**

g. Internal quality control checks, laboratory performance and systems audits and frequency, including:

- i) Method blank(s);
- ii) Laboratory control sample(s);
- iii) Calibration check sample(s);
- iv) Replicate sample(s);
- v) Matrix-spiked sample(s);
- vii) Control charts;
- viii) Surrogate samples;
- ix) Zero and span gases; and
- x) Reagent quality control checks.

h. Preventive maintenance procedures and schedules;

i. Corrective action (for laboratory problems); and

j. Turnaround time.

C. Data Management Plan

The Permittee shall develop and initiate a Data Management Plan to document and track investigation data and results. This plan shall identify and set up data documentation materials and procedures, project file requirements, and project-related progress reporting procedures and documents. The plan shall also provide the format to be used to present the raw data and conclusions of the investigation.

1. Data Record

The data record shall include the following:

- a. Unique sample or field measurement code;
- b. Sampling or field measurement location and sample or measurement type;
- c. Sampling or field measurement raw data;

- d. Laboratory analysis ID number;
- e. Property or component measures; and
- f. Result of analysis (e.g. concentration).

2. Tabular Displays

The following data shall be presented in tabular displays:

- a. Unsorted (raw) data;
- b. Results for each medium, or for each constituent monitored;
- c. Data reduction for statistical analysis, as appropriate;
- d. Sorting of data by potential stratification factors (e.g., location, soil layer, topography); and
- e. Summary data

3. Graphical Displays

The following data shall be presented in graphical formats (e. g., bar graphs, line graphs, area or plan maps, isopleth plots, cross-sectional plots or transits, three dimensional graphs, etc.):

- a. Display sampling location and sampling grid;
- b. Indicate boundaries of sampling area, and area where more data are required;
- c. Display geographical extent of contamination;
- d. Illustrate changes in concentration in relation to distances from the source, time, depth or other parameters; and
- e. Indicate features affecting inter-media transport and show potential receptors.

**DRAFT**

## II. RCRA Facility Investigation (RFI) Requirements

### RCRA Facility Investigation:

The Permittee shall conduct those investigations necessary to: characterize the facility (Environmental Setting); define the source (Source Characterization); define the degree and extent of release of hazardous constituents (Contamination Characterization); and identify actual or potential receptors.

The investigations should result in data of adequate technical content and quality to support the development and evaluation of the corrective action plan if necessary. The information contained in a RCRA Part B permit application and/or RCRA Section 3019 Exposure Information Report may be referenced as appropriate.

All sampling and analyses shall be conducted in accordance with the Sampling and Analysis Plan. All sampling locations shall be documented in a log and identified on a detailed site map.

#### A. Environmental Setting

The Permittee shall collect information to supplement and/or verify Part B information on the environmental setting at the facility. The Permittee shall characterize the following as they relate to identified sources, pathways and areas of releases of hazardous constituents from Solid Waste Management Units.

##### 1. Hydrogeology

The Permittee shall conduct a program to evaluate hydrogeologic conditions at the facility. This program shall provide the following information:

- a. A description of the regional and facility specific geologic and hydrogeologic characteristics affecting ground-water flow beneath the facility, including:
  - i) Regional and facility specific stratigraphy: description of strata including strike and dip, identification of stratigraphic contacts;
  - ii) Structural geology: description of local and regional structural features (e. g., folding, faulting, tilting, jointing, etc.);
  - iii) Depositional history;



- iv) Regional and facility specific ground-water flow patterns; and
  - v) Identification and characterization of areas and amounts of recharge and discharge.
- b. An analysis of any topographic features that might influence the ground-water flow system.
- c. Based on field data, tests, and cores, a representative and accurate classification and description of the hydrogeologic units which may be part of the migration pathways at the facility (i. e., the aquifers and any intervening saturated and unsaturated units), including:
- i) Hydraulic conductivity and porosity (total and effective);
  - ii) Lithology, grain size, sorting, degree of cementation;
  - iii) An interpretation of hydraulic interconnections between saturated zones; and
  - iv) The attenuation capacity and mechanisms of the natural earth materials (e. g., ion exchange capacity, organic carbon content, mineral content etc.).
- d. Based on data obtained from groundwater monitoring wells and piezometers installed upgradient and downgradient of the potential contaminant source, a representative description of water level or fluid pressure monitoring including:
- i) Water-level contour and/or potentiometric maps;
  - ii) Hydrologic cross sections showing vertical gradients;
  - iii) The flow system, including the vertical and horizontal components of flow; and
  - iv) Any temporal changes in hydraulic gradients, for example, due to tidal or seasonal influences.

- e. A description of man-made influences that may affect the hydrology of the site, identifying:
  - i) Local water-supply and production wells with an approximate schedule of pumping; and
  - ii) Man-made hydraulic structures (pipelines, french drains, ditches, etc.).

2. Soils

The Permittee shall conduct a program to characterize the soil and rock units above the water table in the vicinity of contaminant release(s). Such characterization may include, but not be limited to, the following types of information as appropriate:

- a. Surface soil distribution;
- b. Soil profile, including ASTM classification of soils;
- c. Transects of soil stratigraphy;
- d. Hydraulic conductivity (saturated and unsaturated);
- e. Relative permeability;
- f. Bulk density;
- g. Porosity;
- h. Soil sorption capacity;
- i. Cation exchange capacity (CEC);
- j. Soil organic content;
- k. Soil pH;
- l. Particle size distribution;
- m. Depth of water table;
- n. Moisture content;
- o. Effect of stratification on unsaturated flow;
- p. Infiltration;
- q. Evapotranspiration;
- r. Storage capacity;
- s. Vertical flow rate; and
- t. Mineral content.

3. Surface Water and Sediment

The Permittee shall conduct a program to characterize the surface water bodies in the vicinity of the facility. Such characterization may include, but not be limited to, the following activities and information:

- a. Description of the temporal and permanent surface water bodies including:

**DRAFT**

- i) For lakes and estuaries: location, elevation, surface area, inflow, outflow, depth, temperature stratification, and volume;
  - ii) For impoundments: location, elevation, surface area, depth, volume, freeboard, and construction and purpose;
  - iii) For streams, ditches, and channels: location, elevation, flow, velocity, depth, width, seasonal fluctuations, flooding tendencies (i. e., 100 year event), discharge point(s), and general contents.
  - iv) Drainage patterns; and
  - v) Evapotranspiration.
- b. Description of the chemistry of the natural surface water and sediments. This includes determining the pH, total dissolved solids, total suspended solids, biological oxygen demand, alkalinity, conductivity, dissolved oxygen profiles, nutrients, chemical oxygen demand, total organic carbon, specific contaminant concentrations, etc.
- c. Description of sediment characteristics including:
- i) Deposition area;
  - ii) Thickness profile; and
  - iii) Physical and chemical parameters (e. g., grain size, density, organic carbon content, ion exchange capacity, pH, etc.)

#### 4. Air

The Permittee shall provide information characterizing the climate in the vicinity of the facility. Such information may include, but not be limited to:

- a. A description of the following parameters:
- i) Annual and monthly rainfall averages;
  - ii) Monthly temperature averages and extremes;
  - iii) Wind speed and direction;

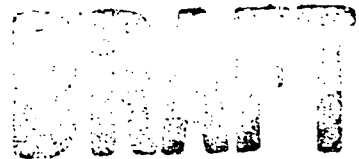

- iv) Relative humidity/dew point;
  - v) Atmospheric pressure;
  - vi) Evaporation data;
  - vii) Development of inversions; and
  - viii) Climate extremes that have been known to occur in the vicinity of the facility, including frequency of occurrence. (i. e. Hurricanes)
- b. A description of topographic and man-made features which affect air flow and emission patterns, including:
- i) Ridges, hills or mountain areas;
  - ii) Canyons or valleys;
  - iii) Surface water bodies (e. g. rivers, lakes, bays, etc.); and
  - iv) Buildings.

B. Source Characterization

For those sources from which releases of hazardous constituents have been detected the Permittee shall collect analytical data to completely characterize the wastes and the areas where wastes have been placed, to the degree that is possible without undue safety risks, including: type, quantity; physical form; disposition (containment or nature of deposits); and facility characteristics affecting release (e. g., facility security, and engineering barriers). This shall include quantification of the following specific characteristics, at each source area:

1. Unit/Disposal Area Characteristics:

- a. Location of unit/disposal area;
- b. Type of unit/disposal area;
- c. Design features;
- d. Operating practices (past and present)
- e. Period of operation;
- f. Age of unit/disposal area;
- g. General physical conditions; and
- h. Method used to close the unit/disposal area.

**DRAFT**

2. Waste Characteristics:

- a. Type of wastes placed in the unit;
  - i) Hazardous classification (e. g., flammable, reactive, corrosive, oxidizing or reducing agent);
  - ii) Quantity; and
  - iii) Chemical composition.
- b. Physical and chemical characteristics such as;
  - i) Physical form (solid, liquid, gas);
  - ii) Physical description (e. g., powder, oily sludge);
  - iii) Temperature;
  - iv) pH;
  - v) General chemical class (e. g., acid, base, solvent);
  - vi) Molecular weight;
  - vii) Density;
  - viii) Boiling point;
  - ix) Viscosity;
  - x) Solubility in water;
  - xi) Cohesiveness of the waste; and
  - xii) Vapor pressure.
- c. Migration and dispersal characteristics of the waste such as:
  - i) Sorption capability;
  - ii) Biodegradability, bioconcentration, biotransformation;
  - iii) Photodegradation rates;

**DRAFT**

- iv) Hydrolysis rates; and
- v) Chemical transformations.

The Permittee shall document the procedures used in making the above determinations.

C. Characterization of Releases of Hazardous Constituents

The Permittee shall collect analytical data on groundwater, soils, surface water, sediment, and subsurface gas contamination in the vicinity of the facility in accordance with the sampling and analysis plan as required above. These data shall be sufficient to define the extent, origin, direction, and rate of movement of contamination. Data shall include time and location of sampling, media sampled, concentrations found, conditions during sampling, and the identity of the individuals performing the sampling and analysis. The Permittee shall address the following types of contamination at the facility:

1. Groundwater Contamination

The Permittee shall conduct a groundwater investigation to characterize any plumes of contamination detected at the facility. This investigation shall at a minimum provide the following information:

- a. A description of the horizontal and vertical extent of any plume(s) of hazardous constituents originating from or within the facility;
- b. The horizontal and vertical direction of contamination movement;
- c. The velocity of contaminant movement;
- d. The horizontal and vertical concentration profiles of hazardous constituents in the plume(s);
- e. An evaluation of factors influencing the plume movement; and
- f. An extrapolation of future contaminant movement.

The Permittee shall document the procedures used in making the above determinations (e. g., well design, well construction, geophysics, modeling, etc.).

**DRAFT**

2. Soil Contamination

The Permittee shall conduct an investigation to characterize the contamination of the soil and rock units above the saturated zone in the vicinity of any contaminant release. The investigation may include the following information:

- a. A description of the vertical and horizontal extent of contamination;
- b. A description of appropriate contaminant and soil chemical properties within the contaminant source area and plume. This may include contaminant solubility, speciation, absorption, leachability, exchange capacity, biodegradability, hydrolysis, photolysis, oxidation and other factors that might affect contaminant migration and transformation;
- c. Specific contaminant concentrations;
- d. The velocity and direction of contaminant movement; and
- e. An extrapolation of future contaminant movement.

The Permittee shall document the procedures used in making the above determinations.

3. Surface Water and Sediment Contamination

The Permittee shall conduct a surface water investigation to characterize contamination in surface water bodies resulting from releases of hazardous constituents at the facility.

The investigation may include, but not be limited to, the following information:

- a. A description of the horizontal and vertical extent of any plume(s) originating from the facility, and the extent of contamination in underlying sediments;
- b. The horizontal and vertical direction of contaminant movement;
- c. The contaminant velocity;

**DRAFT**

- d. An evaluation of the physical, biological and chemical factors influencing contaminant movement;
- e. An extrapolation of future contaminant movement; and
- f. A description of the chemistry of the contaminated surface waters and sediments. This includes determining the pH, total dissolved solids, specific contaminant concentrations, etc.

4. Air Contamination

The Permittee shall conduct an investigation to characterize gaseous releases of hazardous constituents into the atmosphere or any structures or buildings. This investigation may provide the following information:

- a. A description of the horizontal and vertical direction and velocity of contaminant movement;
- b. The rate and amount of the release; and
- c. The chemical and physical composition of the contaminant(s) released, including horizontal and vertical concentration profiles.

The Permittee shall document the procedures used in making the above determinations.

D. Potential Receptors

The Permittee shall collect data describing the human populations and environmental systems that are susceptible to contaminant exposure from the facility. Chemical analysis of biological samples and/or data on observable effects in ecosystems may also be obtained as appropriate. The following characteristics shall be identified:

- 1. Current local uses and planned future uses of groundwater:
  - a. Type of use (e. g., drinking water source: municipal or residential, agricultural, domestic/non-potable, and industrial); and

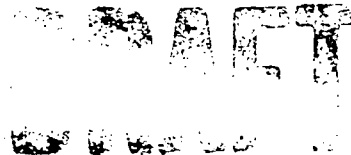



- b. Location of ground water users, to include withdrawal and discharge wells, within one mile of the impacted area.

The above information should also indicate the aquifer or hydrogeologic unit used and/or impacted for each item.

- 2. Current local uses and planned future uses of surface waters directly impacted by the facility:
  - a. Domestic and municipal (e. g., potable and lawn/gardening watering);
  - b. Recreational (e. g. swimming, fishing);
  - c. Agricultural;
  - d. Industrial; and
  - e. Environmental (e. g., fish and wildlife propagation).
- 3. Human use of or access to the facility and adjacent lands, including but not limited to:
  - a. Recreation;
  - b. Hunting;
  - c. Residential;
  - d. Commercial; and
  - e. Relationship between population locations and prevailing wind direction.
- 4. A general description of the biota in surface water bodies on, adjacent to, or affected by the facility.
- 5. A general description of the ecology within area the area adjacent to the facility.
- 6. A general demographic profile of the people who use or have access to the facility and adjacent land, including, but not limited to: age; sex; and sensitive subgroups.
- 7. A description of any known or documented endangered or threatened species near the facility.

APPENDIX C

Corrective Measures Study (CMS)  
Plan Outline

APPENDIX C

CORRECTIVE MEASURE STUDY (CMS) PLAN OUTLINE

- I. Identification and Development of the Corrective Measure Alternatives
  - A. Description of Current Situation
  - B. Establishment of Corrective Action Objectives
  - C. Screening of Corrective Measures Technologies
  - D. Identification of the Corrective Measure Alternatives
  
- II. Evaluation of the Corrective Measure Alternatives
  - A. Technical/Environmental/Human Health/Institutional
  - B. Cost Estimate
  
- III. Justification and Recommendation of the Corrective Measure or Measures
  - A. Technical
  - B. Environmental
  - C. Human Health
  
- IV. Reports
  - A. Draft
  - B. Final
  - C. Public Review and Final Selection of Corrective Measure

I. IDENTIFICATION AND DEVELOPMENT OF THE CORRECTIVE MEASURES ALTERNATIVES

Based on the results of the RCRA Facility Investigation and consideration of the identified potential corrective measure technologies, the Permittee shall identify, screen and develop the alternatives for removal, containment, treatment and/or other remediation of the contamination based on the objectives established for the corrective action.

A. Description of Current Situation

The Permittee shall submit an update to the information describing the current situation at the facility and the known nature and extent of the contamination as documented by the RCRA Facility Investigation (RFI) Report. The Permittee shall provide an update to information presented in the RFI regarding previous response activities and interim measures which have or are being implemented at the facility. The Permittee shall also make a facility-specific statement of the purpose for the response, based on the results of the RFI. The statement of purpose should identify the actual or potential exposure pathways that should be addressed by corrective measures.

B. Establishment of Corrective Action Objectives

The Permittee shall propose facility-specific objectives for the corrective action. These objectives shall be based on public health and environmental criteria, information gathered during the RFI, EPA guidance, and the requirements of any applicable Federal statutes. At a minimum, all corrective actions concerning ground water releases from regulated units must be consistent with, and as stringent as, those required under 40 CFR §264.100.

C. Screening of Corrective Measure Technologies

The Permittee shall review the results of the RFI and assess the technologies which are applicable at the facility. The Permittee shall screen the corrective measure technologies to eliminate those that may prove infeasible to implement, that rely on technologies unlikely to perform satisfactorily or reliably, or that do not achieve the corrective measure objective within a reasonable time period. This screening process focuses on eliminating those technologies which have severe limitations for a given set of waste and site-specific conditions. The screening step may also eliminate technologies based on inherent technology limitations.

**DRAFT**

Site, waste, and technology characteristics which are used to screen inapplicable technologies are described in more detail below:

1. Site Characteristics

Site data should be reviewed to identify conditions that may limit or promote the use of certain technologies. Technologies whose use is clearly precluded by site characteristics should be eliminated from further consideration.

2. Waste Characteristics

Identification of waste characteristics that limit the effectiveness or feasibility of technologies is an important part of the screening process. Technologies clearly limited by these waste characteristics should be eliminated from consideration. Waste characteristics particularly affect the feasibility of in-situ methods, direct treatment methods, and land disposal (on/off-site).

3. Technology Limitations

During the screening process, the level of technology development, performance record, and inherent construction, operation, and maintenance problems should be identified for each technology considered. Technologies that are unreliable, perform poorly, or are not fully demonstrated may be eliminated in the screening process. For example, certain treatment methods have been developed to a point where they can be implemented in the field without extensive technology transfer or development.

D. Identification of the Corrective Measure Alternatives

The Permittee shall develop the Corrective measure alternatives based on the corrective action objectives and analysis of potential corrective measure technologies. The Permittee shall rely on engineering practice to determine which of the previously identified technologies appear most suitable for the site. Technologies can be combined to form the overall corrective action alternatives. The alternatives developed should represent a workable number of option(s) that each appear to adequately address all site problems and corrective action objectives. Each alternative may consist of an individual technology or a combination of technologies. The Permittee shall document the reasons for excluding technologies.

II. EVALUATION OF THE CORRECTIVE MEASURE ALTERNATIVES

The Permittee shall describe each corrective measure alternative that passes through the initial screening and evaluate each corrective measure alternative and its components. The evaluation shall be based on technical, environmental, human health and institutional concerns. The Permittee shall also develop cost estimates of each corrective measure.

**DRAFT**

A. Technical/Environmental/Human Health/Institutional

The Permittee shall provide a description of each corrective measure alternative which includes but is not limited to the following: preliminary process flow sheets; preliminary sizing and type of construction for buildings and structures; and rough quantities of utilities required. The Permittee shall evaluate each alternative in the four following areas:

1. Technical;

The Permittee shall evaluate each corrective measure alternative based on performance, reliability, implementability and safety.

a. The Permittee shall evaluate performance based on the effectiveness and useful life of the corrective measure:

- i) Effectiveness shall be evaluated in terms of the ability to perform intended functions, such as containment, diversion, removal, destruction, or treatment. The effectiveness of each corrective measure shall be determined either through design specifications or by performance evaluation. Any specific waste or site characteristics which could potentially impede effectiveness shall be considered. The evaluation should also consider the effectiveness of combinations of technologies; and
- ii) Useful life is defined as the length of time the level of desired effectiveness can be maintained. Most corrective measure technologies, with the exception of destruction, deteriorate with time. Often, deterioration can be slowed through proper system operation and maintenance; but the technology eventually may require replacement. Each corrective measure shall be evaluated in terms of the projected service lives of its component technologies. Resource availability in the future life of the technology, as well as appropriateness of the technologies, must be considered in estimating the useful life of the project.

b. The Permittee shall provide information on the reliability of each corrective measure including their operation and maintenance requirements and their demonstrated reliability:

- i) Operation and maintenance requirements include the frequency and complexity of necessary operation and maintenance. Technologies requiring frequent or complex operation and maintenance activities should be regarded as less reliable than technologies requiring little or straightforward operation and maintenance. The availability of labor and materials to meet these requirements shall also be considered; and

- ii) Demonstrated and expected reliability is a way of measuring the risk and effect of failure. The Respondent should evaluate whether the technologies have been used effectively under analogous conditions; whether the combination of technologies have been used together effectively; whether failure of any one technology has an immediate impact on receptors; and whether the corrective measure has the flexibility to deal with uncontrollable changes at the site.
- c. The Permittee shall describe the implementability of each corrective measure including the relative ease of installation (constructability) and the time required to achieve a given level of response:
  - i) Constructability is determined by conditions both internal and external to the facility conditions and include such items as location of underground utilities, depth to water table, heterogeneity of subsurface materials, and location of the facility (i.e., remote location vs. a congested urban area). The Permittee shall evaluate what measures can be taken to facilitate construction under these conditions. External factors which affect implementation include the need for special permits or agreements, equipment availability, and the location of suitable off-site treatment or disposal facilities; and
  - ii) Time has two components that shall be addressed: the time it takes to implement a corrective measure and the time it takes to actually see beneficial results. Beneficial results are defined as the reduction of contaminants to some acceptable, pre-established level.
- d. The Permittee shall evaluate each corrective measure alternative with regard to safety. This evaluation shall include threats to the safety of nearby communities and environments as well as those to workers during implementation. Factors to consider are fire, explosion, and exposure to hazardous substances.

## 2. Environmental;

The Permittee shall perform an Environmental Assessment for each alternative. The Environmental Assessment shall focus on the facility conditions and pathways of contamination actually addressed by each alternative. The Environmental Assessment for each alternative will include, at a minimum, an evaluation of: the short- and long-term beneficial and adverse effects of the response alternative; any adverse effects on environmentally sensitive areas; and an analysis of measures to mitigate adverse effects.

### 3. Human Health

The Permittee shall assess each alternative in terms of the extent to which it mitigates short-and long-term potential exposure to any residual contamination and protects human health both during and after implementation of the corrective measure. The assessment will describe the concentrations and characteristics of the contaminants on-site, potential exposure routes, and potentially affected population. Each alternative will be evaluated to determine the level of exposure to contaminants and the reduction over time. For management of mitigation measures, the relative reduction of impact will be determined by comparing residual levels of each alternative with existing criteria, standards, or guidelines acceptable to EPA.

### 4. Institutional

The Permittee shall assess relevant institutional needs for each alternative. Specifically, the effects of Federal, state and local environmental and public health standards, regulations, guidance, advisories, ordinances, or community relations on the design, operation, and timing of each alternative. If the selected remedy is capping and closure in place, a notation must be made in the land deed.

### B. Cost Estimate

The Permittee shall develop an estimate of the cost of each corrective measure alternative (and for each phase or segment of the alternative). The cost estimate shall include both capital and operation and maintenance costs.

1. Capital costs consist of direct (construction) and indirect (nonconstruction and overhead) costs.

a. Direct capital costs include:

- i) Construction costs: Costs of materials, labor (including fringe benefits and worker's compensation), and equipment required to install the corrective measure.
- ii) Equipment costs: Costs of treatment, containment, disposal and/or service equipment necessary to implement the action; these materials remain until the corrective action is complete;
- iii) Land and site-development costs: Expenses associated with purchase of land and development of existing property; and
- iv) Buildings and services costs: Costs of process and nonprocess buildings, utility connections, purchased services, and disposal costs.

**DRAFT**



b. Indirect capital costs include:

- i) Engineering expenses: Costs of administration, design, construction supervision, drafting, and testing of corrective measure alternatives;
- ii) Legal fees and license or permit costs: Administrative and technical costs necessary to obtain licenses and permits for installation and operation;
- iii) Startup and shakedown costs: Costs incurred during corrective measure startup; and
- iv) Contingency allowances: Funds to cover costs resulting from unforeseen circumstances, such as adverse weather conditions, strikes, and inadequate facility characterization.

2. Operation and maintenance costs are post-construction costs necessary to ensure continued effectiveness of a corrective measure. The Permittee shall consider the following operation and maintenance cost components:

- a. Operating labor costs: Wages, salaries, training, overhead, and fringe benefits associated with the labor needed for post-construction operations;
- b. Maintenance materials and labor costs: Costs for labor, parts, and other resources required for routine maintenance of facilities and equipment;
- c. Auxillary materials and energy: Costs of such items as chemicals and electricity for treatment plant operations, water and sewer service, and fuel;
- d. Purchased services: Sampling costs, laboratory fees, and professional fees for which the need can be predicted;
- e. Disposal and treatment costs: Costs of transporting, treating, and disposing of waste materials, such as treatment plant residues, generated during operations;
- f. Administrative costs: Costs associated with administration of corrective measure operation and maintenance not included under other categories;
- g. Insurance, taxes, and licensing costs: Costs of such items as liability and sudden accident insurance; real estate taxes on purchased land or right-of-way; licensing fees for certain technologies; and permit renewal and reporting costs;

**DRAFT**

- h. Maintenance reserve and contingency funds: Annual payments into escrow funds to cover (1) costs of anticipated replacement or rebuilding of equipment and (2) any large unanticipated operation and maintenance costs; and
- i. Other costs: Items that do not fit any of the above categories.

### III. JUSTIFICATION AND RECOMMENDATION OF THE CORRECTIVE MEASURE OR MEASURES

The Permittee shall justify and recommend a corrective measure alternative using technical, human health, and environmental criteria. This recommendation shall include summary tables which allow the alternative or alternatives to be understood easily. Tradeoffs among health risks, environmental effects, and other pertinent factors shall be highlighted. The Regional Administrator will select the corrective measure alternative or alternatives to be implemented based on the results obtained from work completed under Section II and III. At a minimum, the following criteria will be used to justify the final corrective measure or measures.

#### A. Technical

1. Performance - corrective measure or measures which are most effective at performing their intended functions and maintaining the performance over extended periods of time will be given preference;
2. Reliability - corrective measure or measures which do not require frequent or complex operation and maintenance activities and that have proved effective under waste and facility conditions similar to those anticipated will be given preference;
3. Implementability - corrective measure or measures which can be constructed and operating to reduce levels of contamination to attain or exceed applicable standards in the shortest period of time will be preferred; and
4. Safety - corrective measure or measures which pose the least threat to the safety of nearby residents and environments as well as workers during implementation will be preferred.

#### B. Human Health

The corrective measure(s) must comply with existing U.S. EPA criteria, standards, or guidelines for the protection of human health. Corrective measures which provide the minimum level of exposure to contaminants and the maximum reduction in exposure with time are preferred.

C. Environmental

The corrective measure(s) posing the least adverse impact (or greatest improvement) over the shortest period of time on the environment will be favored.

IV. REPORTS

The Permittee shall prepare a Corrective Measure Study Report presenting the results obtained from Sections I through III and recommending a corrective measure alternative. Copies of the preliminary report shall be provided by the Permittee to the Regional Administrator (RA) for review and approval.

A. Draft

The Report shall at a minimum include:

1. A description of the facility;
  - a. Site topographic map & preliminary layouts.
2. A summary of the corrective measure(s) and rationale for selection;
  - a. Description of the corrective measure(s) and rationale for selection;
  - b. Performance expectations;
  - c. Preliminary design criteria and rationale;
  - d. General operation and maintenance requirements; and
  - e. Long-term monitoring requirements.
3. A summary of the RCRA Facility Investigation and impact on the selected corrective measure or measures;
  - a. Field studies (ground-water, surface water, soil, air); and
  - b. Laboratory studies (bench scale, pick scale).

**DRAFT**

4. Design and Implementation Precautions;
  - a. Special technical problems;
  - b. Additional engineering data required;
  - c. Permits and regulatory requirements;
  - d. Access, easements, right-of-way;
  - e. Health and safety requirements; and
  - f. Community relations activities.
5. Cost Estimates and Schedules;
  - a. Capital cost estimate;
  - b. Operation and maintenance cost estimate; and
  - c. Project schedule (design, construction, operation).

Copies of the draft shall be provided by the Permittee to EPA.

B. Final

The Permittee shall finalize the Corrective Measure Study Report incorporating comments received from EPA on the Draft Corrective Measure Study Report. The report shall become final upon approval by the RA.

C. Public Review and Final Selection of Corrective Measures

Upon receipt of the Final Corrective Measure Study Report, EPA shall announce its availability to the public for review and comment. At the end of the comment period, the RA shall review the comments and then inform the Permittee of the final decision as to the approved Corrective Measures to be implemented.

**DRAFT**

APPENDIX D

SCHEDULE OF COMPLIANCE

APPENDIX D

Schedule of Compliance

<u>Schedule of Compliance</u>	<u>Due Date</u>
Notification of Newly Identified SWMUs and AOCs Condition II.B.1 and Condition II.B.2.	Within <u>fifteen (15)</u> calendar days of discovery
SWMU Assessment Report Condition II.B.3.	Within <u>ninety (90)</u> calendar days of notification
Notification for Newly Discovered Releases at Previously Identified SWMUs and AOCs Condition II.C.1.	Within <u>fifteen (15)</u> calendar days of discovery
Confirmatory Sampling Workplan for SWMUs identified in APPENDIX A-3 Condition II.D.1	Within <u>sixty (60)</u> calendar days after effective date of permit
Confirmatory Sampling Report Condition II.D.4.	Within <u>sixty (60)</u> calendar days after approval of the CS Workplan
RFI Workplan for SWMU(s) identified in APPENDIX A-1, Condition II.E.1.a	Within <u>one hundred twenty (120)</u> calendar days after receipt of notification by Regional Administrator
RFI Workplan for SWMU(s) and AOC(s) identified under Condition II.B.4., Condition II.C.2., and Condition II.D.5. Condition II.E.1.b.	Within <u>ninety (90)</u> calendar days after receipt of notification by RA which SWMUs or AOCs require an RFI
RFI Progress Reports Condition II.E.3.a.	Quarterly, beginning <u>ninety (90)</u> calendar days from the start date specified by the RA*
Draft RFI Report Condition II.E.3.b.	In accordance with the approved RFI Workplan

Schedule of Compliance	Due Date
Final RFI Report Condition II.E.3.b.	Within thirty (30) calendar days after receipt of RA comments on Draft RFI Report
Interim Measures Plan Condition II.F.1.a.	Within thirty (30) calendar days of notification by RA
Interim Measures Progress Reports Condition II.F.3.a.	Semi-annually, beginning 180 days from the start date specified by the RA**
Interim Measure Report Condition II.F.3.b.	Within ninety (90) calendar days of completion of Interim Measures
CMS Plan Condition II.G.1.a.	Within ninety (90) calendar days of notification by RA that a CMS is needed
Implementation of CMS Plan	Within fifteen (15) calendar days after receiving RA's written approval of CMS Plan
Draft CMS Report Condition II.G.3.a.	Within ninety (90) calendar days of RA's approval of CMS Plan
Final CMS Report Condition II.G.3.a.	Within thirty (30) calendar days of RA's comment on draft CMS Report
Demonstration of Financial Assurance Condition II.H.3.	Within one hundred twenty (120) calendar days after permit modification for CMS remedy
Imminent Hazard Report Condition II.J.1. and II.J.2.	Oral within 24 hours; Written within fifteen (15) calendar days
Waste Minimization Certification Condition III	Annually from effective date of permit

The above reports must be signed and certified in accordance with 40 CFR §270.11.

\* This applies to Plan execution that requires more than one hundred eighty (180) calendar days.

\*\*This applies to Workplan execution that requires more than one year.

APPENDIX E

Modification of the Corrective Action  
Schedule of Compliance

**DRAFT**



MODIFICATION OF THE CORRECTIVE ACTION SCHEDULE OF COMPLIANCE

- I. If at any time the Regional Administrator determines that modifications of the Corrective Action Schedule of Compliance is necessary, he or she may initiate a modification to the Schedule of Compliance according to this procedure. If the Regional Administrator initiates a modification, he or she shall:
  - A. Notify the Permittee in writing of the proposed modification and the date by which comments on the proposed modification must be received; and
  - B. Publish a notice of the proposed modification in a locally distributed newspaper, mail a notice to all persons on the facility mailing list maintained according to 40 CFR §124.10(c)(viii), and place a notice in the facility's information repository (i.e., a central source of all pertinent documents concerning the remedial action, usually maintained at the facility or some other public place, such as a public library, that is accessible to the public) if one is required.
    1. If the Regional Administrator receives no written comment on the proposed modification, the modification shall become effective five (5) calendar days after the close of the comment period.
    2. If the Regional Administrator receives written comment on the proposed modification, the Regional Administrator shall make a final determination concerning the modification after the end of the comment period.
  - C. Notify the Permittee in writing of the final decision.
    1. If no written comment was received, the Regional Administrator shall notify individuals on the facility mailing list in writing that the modification has become effective and shall place a copy of the modified Corrective Action Schedule of Compliance in the information repository, if a repository is required for the facility.
    2. If written comment was received, the Regional Administrator shall provide notice of the final modification decision in a locally distributed newspaper and place a copy of the modified Corrective Action Schedule of Compliance in the information repository, if a repository is required for the facility.

**DRAFT**

II. Modifications that are initiated and finalized by the Regional Administrator according to this procedure shall not be subject to administrative appeal.

III. Modifications to the Corrective Action Schedule of Compliance do not constitute a reissuance of the Permit.

APPENDIX F

Waste Minimization Objectives

5. Technology Transfer

- ° Description of efforts to seek and exchange technical information on waste minimization from other parts of the company, other firms, trade associations, technical assistance programs, and professional consultants.

6. Program Evaluation

- ° Description of types and amounts of hazardous waste reduced or recycled.
- ° Analysis and quantification of progress made relative to each performance goal established and each reduction technique to be implemented.
- ° Amendments to waste minimization plan and explanation.
- ° Explanation and documentation of reduction efforts completed or in progress before development of the waste minimization plan.
- ° Explanation and documentation regarding impediments to hazardous waste reduction specific to the individual facility.

References: "Draft Guidance to Hazardous Waste Generators on the Elements of a Waste Minimization Program", 54 FR 25056, June 12, 1989.

"Waste Minimization Opportunity Assessment Manual", EPA/625/7-88/003, July 1988.

**DRAFT**

## APPENDIX F

### Waste Minimization Certification Objectives

The Waste Minimization Program should include the following elements:

#### 1. Top Management Support

- ° Dated and signed policy describing management support for waste minimization and for implementation of a waste minimization plan.
- ° Description of employee awareness and training programs designed to involve employees in waste minimization planning and implementation to the maximum extent feasible.
- ° Description of how a waste minimization plan has been incorporated into management practices so as to ensure ongoing efforts with respect to product design, capital planning, production operations, and maintenance.

#### 2. Characterization of Waste Generation

- ° Identification of types, amounts, and hazardous constituents of waste streams, with the source and date of generation.

#### 3. Periodic Waste Minimization Assessments

- ° Identification of all points in a process where materials can be prevented from becoming a waste, or can be recycled.
- ° Identification of potential waste reduction and recycling techniques applicable to each waste, with a cost estimate for capital investment and implementation.
- ° Description of technically and economically practical waste reduction/recycling options to be implemented, and a planned schedule for implementation.
- ° Specific performance goals, preferably quantitative, for the source reduction of waste by stream. Whenever possible, goals should be stated as weight of waste generated per standard unit of production, as defined by the generator.

#### 4. Cost Allocation System

- ° Identification of waste management costs for each waste, factoring in liability, transportation, recordkeeping, personnel, pollution control, treatment, disposal, compliance and oversight costs to the extent feasible.
- ° Description of how departments are held accountable for the wastes they generate.
- ° Comparison of waste management costs with costs of potential reduction and recycling techniques applicable to each waste.

Attachment 1



Post-It™ brand fax transmittal memo 7671 # of pages > 13

To: Susan Zazzali	From: Melissa Hebert
Co.	Co.
Dept.	Phone #
Fax # 404-347-5205	Fax # 4702

**FEDERAL EXPRESS**

August 1, 1991  
91 MH-225

Mr. James H. Scarbrough, P.E., Chief  
RCRA and Federal Facilities Branch  
Waste Management Division - U.S. EPA/ Region IV  
345 Courtland Street  
Atlanta, GA 30365

Subject: RCRA Air Emissions Standards  
Tampa, FL Service Center (3-163-01)

Dear Mr Scarbrough:

This letter has been prepared to forward information as required under 40 CFR 270.24 and 270.25 for the above referenced facility.

Safety-Kinetics Tampa facility does not have process vents to which subpart AA or part 26 applies, so section 270.24 is not applicable.

The following information is required under section 270.25:

270.25(a)

1. Equipment is associated with the 15,000 gallon used mineral spirits tank and the proposed 20,000 gallon used antifreeze tank.
2. A site plan identifying the hazardous waste management units at the facility is enclosed. Also enclosed are complete equipment inventory forms listing each piece of regulated equipment.
3. Types of equipment include pumps, flanges and valves.
4. The hazardous waste streams are spent mineral spirits and spent antifreeze which can be considered to contain 100 % organics. The spent antifreeze however, can contain up to 1/3 water.
5. The hazardous waste state of mineral spirits and antifreeze is liquid.

6. The equipment is considered to be heavy liquid service (mineral spirits vapor pressure is 2 mm Hg or 0.01 kPa). Compliance with the standard (264.1058) will be achieved through daily facility inspections and, if required, leak detection monitoring and repair. A copy of the daily inspection record and leak detection and repair record for equipment is enclosed.

Sections 270.25(b), (c), and (e) are not applicable to Safety-Kleen's Tampa Facility.

270.25(d)

Safety-Kleen maintains in the facility, an operating record. This record provides a place by which the required information is recorded under 264.1064. The enclosed forms and plans contain the necessary information.

Please note, the ethylene glycol tank has not been constructed. Since the design of tanks and piping configurations generally conforms to a standard configuration, a proposed piping isometric is in the process of being prepared. This drawing and associated information will be forwarded immediately upon completion.

Thank you for your patience in this matter. I am available on extension 2228 if you have any questions or require further information.

Sincerely,

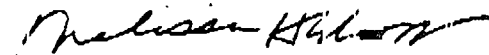

Melissa Hlebasko  
Environmental Permit Writer

cc: S. Zazalli, EPA Region VI  
Branch Manager (163-01)  
J. Hartline  
F. Stockbarger  
C. Norton  
W. Crawford, RDE  
Part B File  
Chron. File



**Figure I.B.3-1  
Site Layout Map  
Safety-Kleen Corp. Facility  
Tampa, Florida**

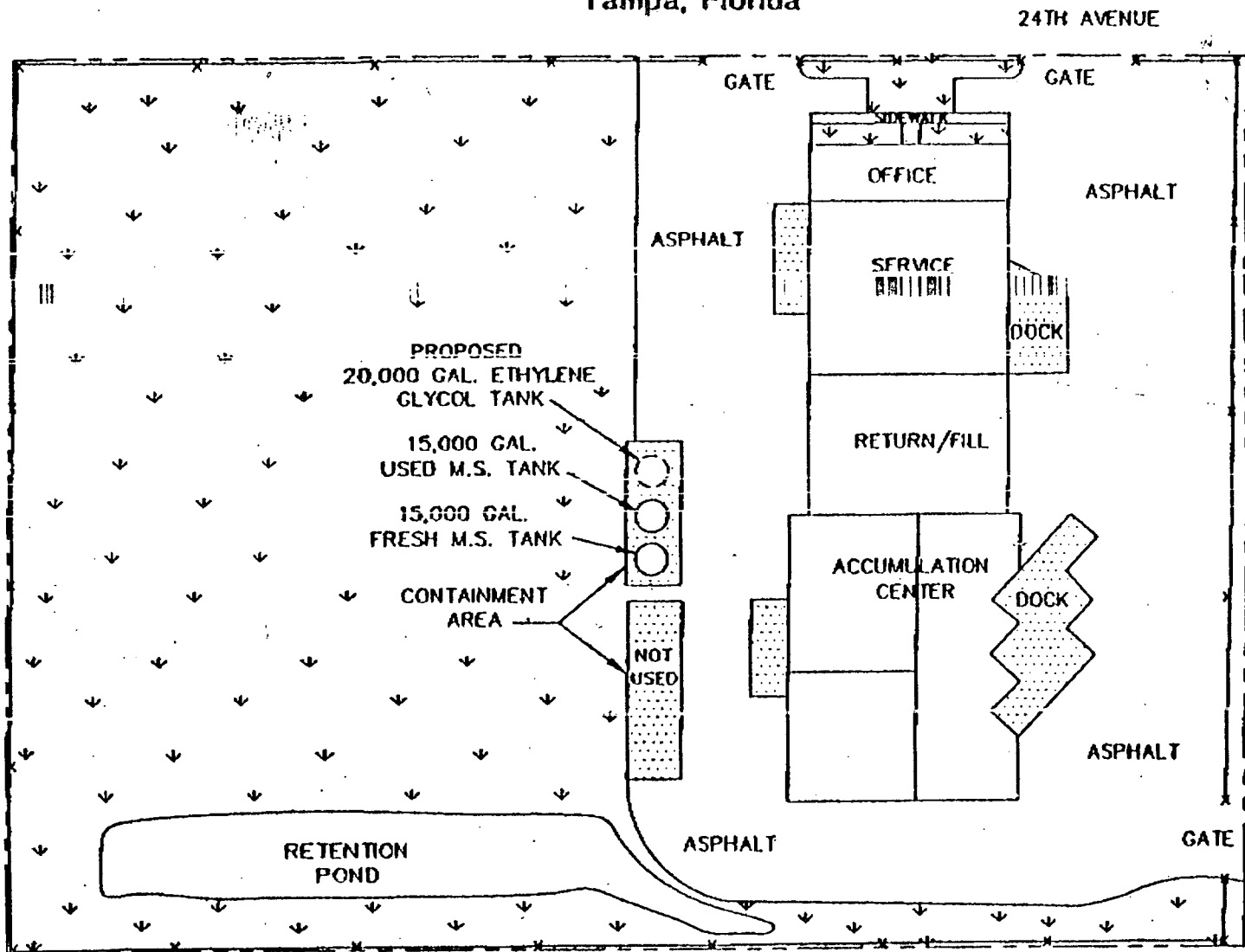

24TH AVENUE

54TH STREET

**LEGEND**

- PROPERTY BOUNDARY
- x-x-x- FENCE
- ↓ ↓ ↓ GRASS
- ▨ CONCRETE
- ▨ M.S. MINERAL SPIRITS



102270/MS6-1157 07-01101







## VALVE LIST

DATE July 31, 1991BRANCH # 3-163-01PREPARER'S  
SIGNATURE R. Hildt

VALVE SIZE	INDIVIDUAL VALVE NUMBER	VALVE TYPE	HAZARDOUS WASTE MANAGEMENT UNIT	LOCATION
3"	2	GATE	ANCILLARY EQUIPMENT - PIPING	Refer to site plan and piping isometric drawings
3"	3	CHECK	"	"
3"	4	GATE	SPENT MINERAL SPIRITS TANK	"
3"	5	GATE	"	"
2"	8	GATE	ANCILLARY EQUIPMENT - RETURN + FILL	"
1 1/2"	10	BALL	"	"
2"	11	GATE	"	"
1 1/2"	12	GATE	"	"
2"	14	GATE	"	"
1 1/2"	16	BALL	"	"
1 1/2"	18	BALL	"	"
2"	20	BALL	"	"
2"	21	GATE	"	"
2"	23	BALL	"	"

# EQUIPMENT INVENTORY

TO BE FILLED OUT AND KEPT IN THE OPERATING RECORD (FILE 1570) WITH THE SITE PLAN AND PUMP AND VALVE LIST

Listed on the attached pump list and valve list is all equipment at the facility which is subject to the requirements of 40 CFR 264 and 265, Subpart BB. The equipment is also identified on the attached site plan.

The hazardous waste influent to and effluent from the hazardous waste management unit(s) is spent mineral spirits (D001, D004-D017, D018, D019, D021-D030 and D032-D043). Tanks are used for storage of spent mineral spirits which is usually 100% by weight organic. The vapor pressure of mineral spirits at 68° F is 0.27 kPa (equivalent to 2 mm Hg - see MSDS and the attached EPA guidance document page). The waste stream has a vapor pressure equal or lower than that of the clean mineral spirits due to contamination during use with oil, grease and sediment and it is in a liquid state at the equipment, so all equipment is in contact with materials defined as heavy liquid under the cited regulations.

Equipment associated with the waste antifreeze tank(s) is also in heavy liquid service. Ethylene glycol has a vapor pressure at 68° of .08 mm Hg or 0.01 kPa and is usually 100% organic.

Compliance with the standard (264.1058) will be achieved through daily facility inspections, and if required, leak detection monitoring and repair. The facility inspection record has been updated to include a detailed daily equipment inspection. Records of equipment monitoring and repair are maintained on a separate form in the operating record.

Post-It™ brand fax transmittal memo 7671 # of pages 136

To	Susan Zazzali	From	Melissa Hebsack
Co.		Co.	
Dept.	4486	Phone #	
Fax #	404-347-5205	Fax #	

4702

**LEAK DETECTION AND REPAIR RECORD**

EQUIPMENT I.D.# \_\_\_\_\_  
 DESCRIPTION \_\_\_\_\_

BRANCH # \_\_\_\_\_

HOW WAS POTENTIAL OR ACTUAL LEAK DETECTED? \_\_\_\_\_  
 \_\_\_\_\_

DATE

INSPECTOR'S SIGNATURE

DESCRIBE THE POTENTIAL OR ACTUAL LEAK: \_\_\_\_\_  
 \_\_\_\_\_

INSTRUMENT MONITORING WITHIN FIVE DAYS

(1.) RESULTS \_\_\_\_\_

REPAIR ATTEMPT METHOD \_\_\_\_\_  
 (2.) RESULTS \_\_\_\_\_

REPAIR ATTEMPT METHOD \_\_\_\_\_  
 (3.) RESULTS \_\_\_\_\_

DATE OF SUCCESSFUL REPAIR (must be completed w/in 15 days)

(4.) METHOD \_\_\_\_\_  
 RESULTS \_\_\_\_\_

FOLLOWUP MONTHLY MONITORING FOR VALVES

(5.) RESULTS \_\_\_\_\_

(6.) RESULTS \_\_\_\_\_

**MONITORING SUMMARY**

(REFERENCE NUMBER - SEE ABOVE)

(1)      (2)      (3)      (4)      (5)      (6)

INSTRUMENT #/OPERATOR	_____	_____	_____	_____	_____	_____
CALIBRATION	_____	_____	_____	_____	_____	_____
BACKGROUND READING	_____	_____	_____	_____	_____	_____
READING AT EQUIPMENT	_____	_____	_____	_____	_____	_____
LEAK DETECTED?	_____	_____	_____	_____	_____	_____

ATTACH ANY DOCUMENTATION PREPARED BY THE CONSULTANT

INSPECTOR'S NAME/TITLE: \_\_\_\_\_

INSPECTOR'S SIGNATURE: \_\_\_\_\_

	MON	TUES	WED	THURS	FRI
--	-----	------	-----	-------	-----

DATE: (M/D/Y) \_\_\_\_\_

TIME: \_\_\_\_\_

Pump, Valve or Flange Number

1	A	N	A	N	A	N
2	A	N	A	N	A	N
3	A	N	A	N	A	N
4	A	N	A	N	A	N
5	A	N	A	N	A	N
6	A	N	A	N	A	N
7	A	N	A	N	A	N
8	A	N	A	N	A	N
9	A	N	A	N	A	N
10	A	N	A	N	A	N
11	A	N	A	N	A	N
12	A	N	A	N	A	N
13	A	N	A	N	A	N
14	A	N	A	N	A	N
15	A	N	A	N	A	N
16	A	N	A	N	A	N
17	A	N	A	N	A	N
18	A	N	A	N	A	N
19	A	N	A	N	A	N
20	A	N	A	N	A	N
21	A	N	A	N	A	N
22	A	N	A	N	A	N
23	A	N	A	N	A	N
24	A	N	A	N	A	N
25	A	N	A	N	A	N
26	A	N	A	N	A	N
27	A	N	A	N	A	N
28	A	N	A	N	A	N
29	A	N	A	N	A	N
30	A	N	A	N	A	N
31	A	N	A	N	A	N
32	A	N	A	N	A	N
33	A	N	A	N	A	N
34	A	N	A	N	A	N
35	A	N	A	N	A	N

If "N", enter pump, valve or flange # \_\_\_\_\_ and circle appropriate problem: potential leak, actual leak, sticking, wear, does not operate smoothly, other: \_\_\_\_\_

For all leaks and potential leaks, the Leak Detection and Repair Record must be completed.

- \* A = ACCEPTABLE
- N = NOT ACCEPTABLE

Draw a line through I.D. numbers which do not apply.



United States  
Environmental Protection  
Agency

Office of Air Quality  
Planning and Standards  
Research Triangle Park NC 27711

EPA-450/3-89-021  
July 1989



**Hazardous Waste  
TSDI - Technical  
Guidance Document  
for RCRA Air Emission  
Standards for Process  
Vents and Equipment  
Leaks**

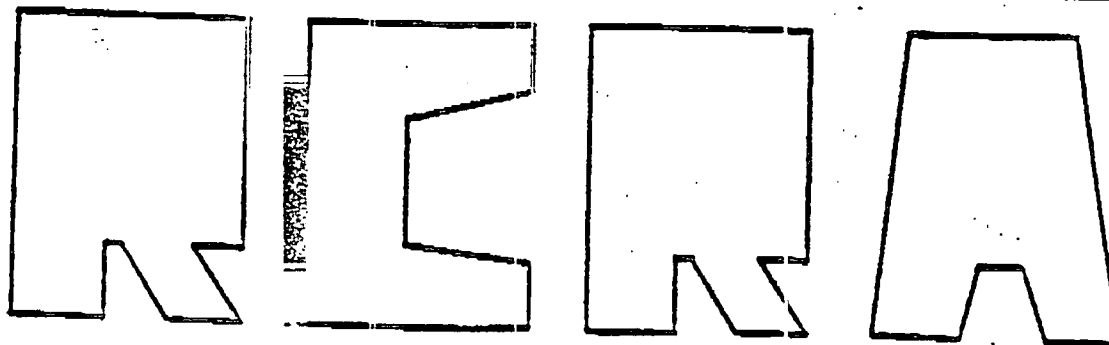
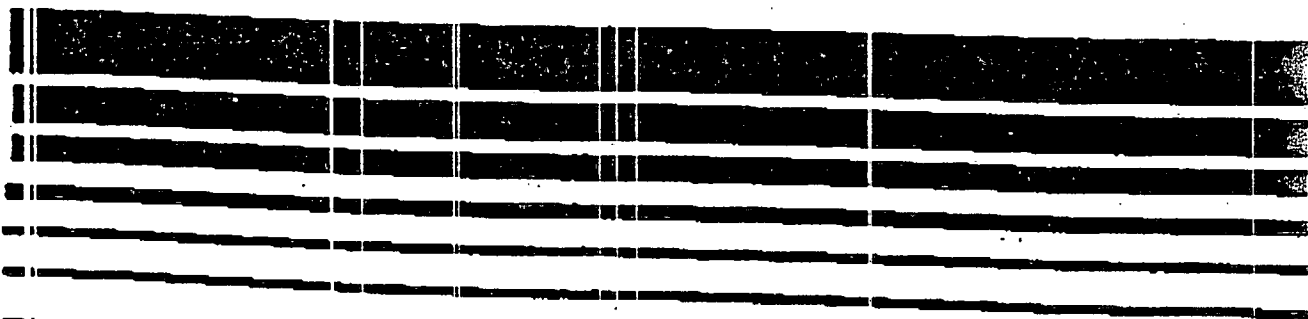

REPRODUCED BY  
U.S. DEPARTMENT OF COMMERCE  
NATIONAL TECHNICAL  
INFORMATION SERVICE  
SPRINGFIELD, VA 22161

TABLE 6-3. VAPOR PRESSURES OF COMMON SOLVENTS

	VP @ 20°C, kPa (mm Hg)		Most appropriate analytical method
<b>Halogenated Solvents</b>			
Methylene chloride	45.2	(340)	EPA Method 8240
1,1,1-Trichloroethane	2.3	(17)	EPA Method 8240
Trichloroethylene	7.8	(59)	EPA Method 8240
Perchloroethylene	1.7	(13)	EPA Method 8240
Methyl ethyl ketone	9.4	(70.6)	EPA Method 8240
Methyl isobutyl ketone	2.1	(16)	EPA Method 8240
Toluene	5.1	(38)	EPA Method 8240
Acetone	24.6	(185)	EPA Method 8240
Xylene(s)	1.3	(9.5)	EPA Method 8240
Mineral spirits	0.27	(2.0)	ASTM E 260
<b>Alcohols</b>			
Isopropyl alcohol	4.1	(31)	ASTM E 260
Methanol	12.7	(96)	ASTM E 260
Ethanol	5.9	(44)	ASTM E 260

VP = vapor pressure.

VOC Air-Emissions Calculations

	Methylene Chloride	1,1,1- Trichloro ethane	Trichloro ethylene	Perchloro ethylene	Mineral Sprites	Acetone	Toluene	Methanol	Ethanol
Atmos. pressure (mm Hg):	760.0	760.0	760.0	760.0	760.0	760.0	760.0	760.0	760.0
Unit weight of air (lbs):	1.0	1.0	1.0	1.0	1.0	1.0	1.0	1.0	1.0
Ambient temperature (°F):	68.0	68.0	68.0	68.0	68.0	68.0	68.0	68.0	68.0
Vapor press. VOC (mm Hg):	311.5	101.9	59.0	12.7	1.28	177.21	21.80	93.74	12.77
<del>Initial weight of VOC</del>	<del>0.0</del>	<del>0.0</del>	<del>0.0</del>	<del>0.0</del>	<del>0.0</del>	<del>0.0</del>	<del>0.0</del>	<del>0.0</del>	<del>0.0</del>
(1) Partial pressure air =	448.5	658.1	701.0	747.3	758.7	582.8	738.2	666.3	747.7
(2) Mole fraction of air =	0.590	0.866	0.922	0.983	0.998	0.767	0.971	0.877	0.944
(3) Pound-moles of air =	0.034	0.034	0.034	0.034	0.034	0.034	0.034	0.034	0.034
(4) Pound-moles, total =	0.058	0.040	0.037	0.035	0.035	0.045	0.034	0.039	0.037
(5) Pound-moles of VOC =	0.024	0.005	0.003	0.001	0.000	0.010	0.003	0.005	0.002
(6) Pounds of VOC =	2.03	0.71	0.36	0.10	0.01	0.61	0.00	0.16	0.09
(7) VOC CONC. PPM (VOL.) =	409,922	134,050	77,609	16,743	1,688	233,176	28,678	123,347	55,622
(8) VOC CONC. PPM (WT.) =	670,453	415,916	276,010	88,717	8,668	378,495	0	134,537	85,361



FEDERAL EXPRESS

August 1, 1991  
91 MH-225

Mr. James H. Scarbrough, P.E., Chief  
RCRA and Federal Facilities Branch  
Waste Management Division - U.S. EPA/ Region IV  
345 Courtland Street NE  
Atlanta, GA 30365

Subject: RCRA Air Emissions Standards  
Tampa, FL Service Center (3-163-01)

Dear Mr Scarbrough:

This letter has been prepared to forward information as required under 40 CFR 270.24 and 270.25 for the above referenced facility.

Safety-Kleen's Tampa facility does not have process vents to which subpart AA of part 264 applies, so section 270.24 is not applicable.

The following information is required under section 270.25:

270.25(a)

1. Equipment is associated with the 15,000 gallon used mineral spirits tank and the proposed 20,000 gallon used antifreeze tank.
2. A site plan identifying the hazardous waste management units at the facility is enclosed. Also enclosed are complete equipment inventory forms listing each piece of regulated equipment.
3. Types of equipment include pumps, flanges and valves.
4. The hazardous waste streams are spent mineral spirits and spent antifreeze which can be considered to contain 100 % organics. The spent antifreeze, however, can contain up to 1/3 water.
5. The hazardous waste state of mineral spirits and antifreeze is liquid.

6. The equipment is considered to be heavy liquid service (mineral spirits vapor pressure is 2 mm Hg or 0.01 kPa). Compliance with the standard (264.1058) will be achieved through daily facility inspections and, if required, leak detection monitoring and repair. A copy of the daily inspection record and leak detection and repair record for equipment is enclosed.

Sections 270.25(b), (c), and (e) are not applicable to Safety-Kleen's Tampa Facility.

270.25(d)

Safety-Kleen maintains in the facility, an operating record. This record provides a place by which the required information is recorded under 264.1064. The enclosed forms and plans contain the necessary information.

Please note, the ethylene glycol tank has not been constructed. Since the design of tanks and piping configurations generally conforms to a standard configuration, a proposed piping isometric is in the process of being prepared. This drawing and associated information will be forwarded immediately upon completion.

Thank you for your patience in this matter. I am available on extension 2228 if you have any questions or require further information.

Sincerely,



Melissa Hlebasko  
Environmental Permit Writer

cc: S. Zazalli, EPA Region VI  
Branch Manager (3-163-01)  
J. Hartline  
F. Stockbarger  
C. Norton  
W. Crawford, FDER  
Part B File  
Chron. File

# Figure I.B.3-1 Site Layout Map Safety-Kleen Corp. Facility Tampa, Florida

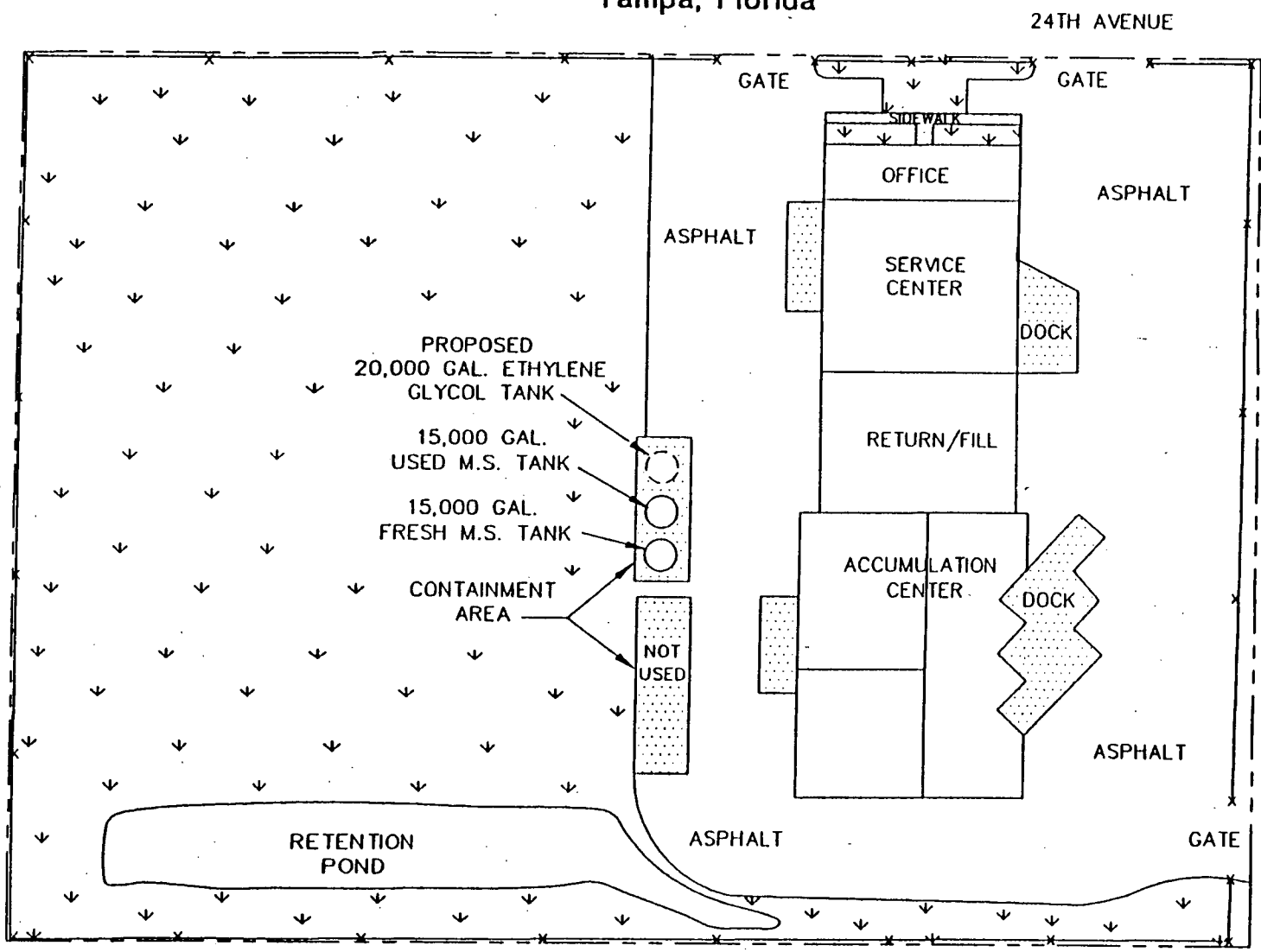

**LEGEND**

- PROPERTY BOUNDARY
- x-x-x- FENCE
- ↓ ↓ ↓ GRASS
- ▭ CONCRETE
- ▭ M.S. MINERAL SPIRITS



**EQUIPMENT SCHEDULE**

MARK	DESCRIPTION
01	2" CARBON
02	2" GATE VALVE
03	2" CHECK VALVE
04	2" GATE VALVE
05	2" GATE VALVE
06	2" INTERNAL EMERGENCY GATE VALVE
07	USED SOLVENT PUMP
08	STRAINER ASSEMBLY
09	2" GATE VALVE
10	RECIRCULATING PUMP
11	1 1/2" BALL VALVE
12	2" GATE VALVE
13	1 1/2" BALL VALVE
14	2" CARBON
15	2" GATE VALVE
16	RECIRCULATING PUMP
17	1 1/2" BALL VALVE
18	1 1/2" BALL VALVE
19	2" CARBON
20	2" BALL VALVE
21	2" GATE VALVE
22	2" CARBON
23	2" BALL VALVE

**GENERAL NOTES**

THIS DRAWING CONTAINS INFORMATION PROPRIETARY TO SAFETY-KLEEN CORPORATION. ANY REPRODUCTION, DISCLOSURE OR USE OF THIS DRAWING IS EXPRESSLY PROHIBITED EXCEPT BY SAFETY-KLEEN OR AS SAFETY-KLEEN MAY AGREE IN WRITING.

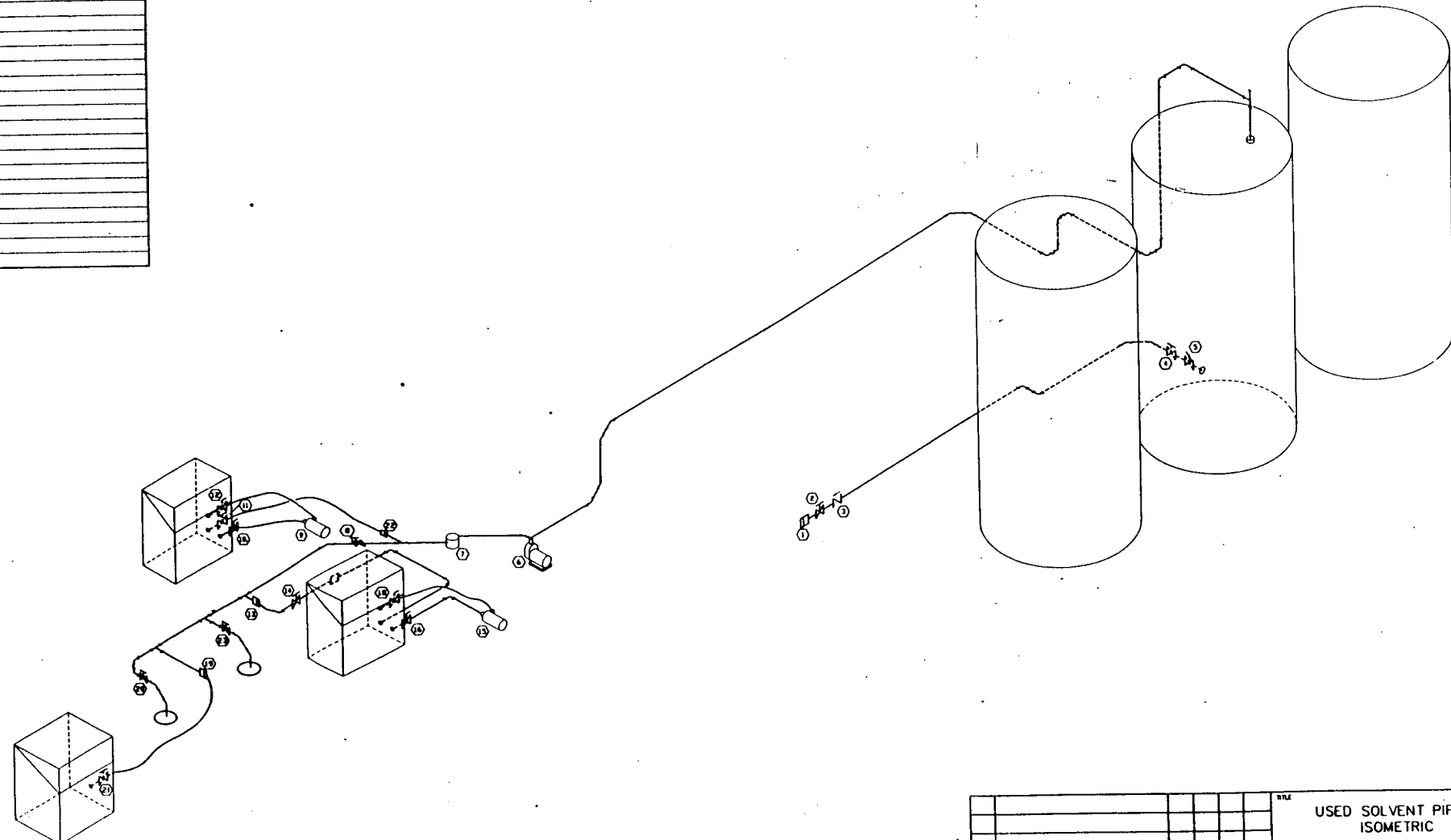

TITLE									
USED SOLVENT PIPING ISOMETRIC									
<b>S SAFETY-KLEEN CORP.</b>									
<small>717 865 TOWN RD. ELK RIVER, MISS. PHONE 769-1617-0448</small>									
SCALE	BY	CHKD	P.L. APPR	DP. APPR	DATE				
1	ADDED TAG 0'S 22 & 23 DELETED TAG 017	HRM	-	-	05/79				
NO	DESCRIPTION	BY	CHK	APPR	DATE	SURFACE CENTER LOCATION		SC-090-REV. NO.	
						TAMPA, FL		316301-2002-01	
<small>REVISIONS</small>									







## VALVE LIST

DATE July 31, 1991BRANCH # 3-163-01PREPARER'S  
SIGNATURE R. Hildner

VALVE SIZE	INDIVIDUAL VALVE NUMBER	VALVE TYPE	HAZARDOUS WASTE MANAGEMENT UNIT	LOCATION
3"	2	GATE	ANCILLARY EQUIPMENT - PIPING	Refer to site plan and piping isometric drawings
3"	3	CHECK	"	"
3"	4	GATE	SPENT MINERAL SPIRITS TANK	"
3"	5	GATE	"	"
2"	8	GATE	ANCILLARY EQUIPMENT - RETURN + FILL	"
1 1/2"	10	BALL	"	"
2"	11	GATE	"	"
1 1/2"	12	GATE	"	"
2"	14	GATE	"	"
1 1/2"	16	BALL	"	"
1 1/2"	18	BALL	"	"
2"	20	BALL	"	"
2"	21	GATE	"	"
2"	23	BALL	"	"

## EQUIPMENT INVENTORY

TO BE FILLED OUT AT THE BRANCH AND KEPT IN THE OPERATING RECORD (FILE 1070) WITH THE SITE PLAN AND PUMP AND VALVE LIST

Listed on the attached pump list and valve list is all equipment at the facility which is subject to the requirements of 40 CFR 264 and 265, Subpart BB. The equipment is also identified on the attached site plan.

The hazardous waste influent to and effluent from the hazardous waste management unit(s) is spent mineral spirits (D001, D004-D011, D018, D019, D021-D030 and D032-D043). Tanks are used for storage of spent mineral spirits which is usually 100% by weight organic. The vapor pressure of mineral spirits at 68° F is 0.27 kPa (equivalent to 2 mm Hg - see MSDS and the attached EPA guidance document page). The waste stream has a vapor pressure equal or lower than that of the clean mineral spirits due to contamination during use with oil, grease and sediment and it is in a liquid state at the equipment, so all equipment is in contact with materials defined as heavy liquid under the cited regulations.

Equipment associated with the waste antifreeze tank(s) is also in heavy liquid service. Ethylene glycol has a vapor pressure at 68° F of .08 mm Hg or 0.01 kPa and is usually 100% organic.

Compliance with the standard (264.1058) will be achieved through daily facility inspections, and if required, leak detection monitoring and repair. The facility inspection record has been updated to include a detailed daily equipment inspection. Records of equipment monitoring and repair are maintained on a separate form in the operating record.

**LEAK DETECTION AND REPAIR RECORD**

EQUIPMENT I.D.# \_\_\_\_\_  
 DESCRIPTION \_\_\_\_\_

BRANCH # \_\_\_\_\_

	<u>DATE</u>	<u>INSPECTOR'S SIGNATURE</u>
HOW WAS POTENTIAL OR ACTUAL LEAK DETECTED? _____	_____	_____

DESCRIBE THE POTENTIAL OR ACTUAL LEAK: \_\_\_\_\_  
 \_\_\_\_\_

INSTRUMENT MONITORING WITHIN FIVE DAYS

(1.) RESULTS \_\_\_\_\_

REPAIR ATTEMPT METHOD \_\_\_\_\_  
 (2.) RESULTS \_\_\_\_\_

REPAIR ATTEMPT METHOD \_\_\_\_\_  
 (3.) RESULTS \_\_\_\_\_

DATE OF SUCCESSFUL REPAIR (must be completed w/in 15 days) \_\_\_\_\_

METHOD \_\_\_\_\_  
 (4.) RESULTS \_\_\_\_\_

FOLLOWUP MONTHLY MONITORING FOR VALVES

(5.) RESULTS \_\_\_\_\_

(6.) RESULTS \_\_\_\_\_

**MONITORING SUMMARY**

(REFERENCE NUMBER - SEE ABOVE)  
 (1) (2) (3) (4) (5) (6)

INSTRUMENT #/OPERATOR	_____	_____	_____	_____	_____	_____
CALIBRATION	_____	_____	_____	_____	_____	_____
BACKGROUND READING	_____	_____	_____	_____	_____	_____
READING AT EQUIPMENT	_____	_____	_____	_____	_____	_____
LEAK DETECTED?	_____	_____	_____	_____	_____	_____

ATTACH ANY DOCUMENTATION PREPARED BY THE CONSULTANT

INSPECTOR'S NAME/TITLE: \_\_\_\_\_

INSPECTOR'S SIGNATURE: \_\_\_\_\_

	MON	TUES	WED	THURS	FRI
DATE: (M/D/Y)	_____	_____	_____	_____	_____
TIME:	_____	_____	_____	_____	_____
<u>Pump, Valve or Flange Number</u>					

1	A	N	A	N	A	N	A	N
2	A	N	A	N	A	N	A	N
3	A	N	A	N	A	N	A	N
4	A	N	A	N	A	N	A	N
5	A	N	A	N	A	N	A	N
6	A	N	A	N	A	N	A	N
7	A	N	A	N	A	N	A	N
8	A	N	A	N	A	N	A	N
9	A	N	A	N	A	N	A	N
10	A	N	A	N	A	N	A	N
11	A	N	A	N	A	N	A	N
12	A	N	A	N	A	N	A	N
13	A	N	A	N	A	N	A	N
14	A	N	A	N	A	N	A	N
15	A	N	A	N	A	N	A	N
16	A	N	A	N	A	N	A	N
17	A	N	A	N	A	N	A	N
18	A	N	A	N	A	N	A	N
19	A	N	A	N	A	N	A	N
20	A	N	A	N	A	N	A	N
21	A	N	A	N	A	N	A	N
22	A	N	A	N	A	N	A	N
23	A	N	A	N	A	N	A	N
24	A	N	A	N	A	N	A	N
25	A	N	A	N	A	N	A	N
26	A	N	A	N	A	N	A	N
27	A	N	A	N	A	N	A	N
28	A	N	A	N	A	N	A	N
29	A	N	A	N	A	N	A	N
30	A	N	A	N	A	N	A	N
31	A	N	A	N	A	N	A	N
32	A	N	A	N	A	N	A	N
33	A	N	A	N	A	N	A	N
34	A	N	A	N	A	N	A	N
35	A	N	A	N	A	N	A	N

If "N", enter pump, valve or flange # \_\_\_\_\_ and circle appropriate problem: potential leak, actual leak, sticking, wear, does not operate smoothly, other: \_\_\_\_\_

For all leaks and potential leaks, the Leak Detection and Repair Record must be completed.

\* A = ACCEPTABLE  
N = NOT ACCEPTABLE

Draw a line through I.D. numbers which do not apply.

United States  
Environmental Protection  
Agency

Office of Air Quality  
Planning and Standards  
Research Triangle Park NC 27711

EPA-450/3-89-021  
July 1990

Air

---



# Hazardous Waste TSDf - Technical Guidance Document for RCRA Air Emission Standards for Process Vents and Equipment Leaks



RCRA

REPRODUCED BY  
U.S. DEPARTMENT OF COMMERCE  
NATIONAL TECHNICAL  
INFORMATION SERVICE  
SPRINGFIELD, VA 22161

TABLE 6-3. VAPOR PRESSURES OF COMMON SOLVENTS

	VP @ 20°C, kPa (mm Hg)		Most appropriate analytical method
<b>Halogenated Solvents</b>			
Methylene chloride	45.2	(340)	EPA Method 8240
1,1,1-Trichloroethane	2.3	(17)	EPA Method 8240
Trichloroethylene	7.8	(59)	EPA Method 8240
Perchloroethylene	1.7	(13)	EPA Method 8240
Methyl ethyl ketone	9.4	(70.6)	EPA Method 8240
Methyl isobutyl ketone	2.1	(16)	EPA Method 8240
Toluene	5.1	(38)	EPA Method 8240
Acetone	24.6	(185)	EPA Method 8240
Xylene(s)	1.3	(9.5)	EPA Method 8240
Mineral spirits	0.27	(2.0)	ASTM E 260
<b>Alcohols</b>			
Isopropyl alcohol	4.1	(31)	ASTM E 260
Methanol	12.7	(96)	ASTM E 260
Ethanol	5.9	(44)	ASTM E 260

VP = vapor pressure.

VOC Air-Emissions Calculations

	Methylene Chloride	1,1,1-Trichloro ethane	Trichloro ethylene	Perchloro ethylene	Mineral Spirits	Acetone	Toluene	Methanol	Ethanol
Atmos. pressure (mm Hg):	760.0	760.0	760.0	760.0	760.0	760.0	760.0	760.0	760.0
Unit weight of air (lbs):	1.0	1.0	1.0	1.0	1.0	1.0	1.0	1.0	1.0
Ambient temperature (oF):	68.0	68.0	68.0	68.0	68.0	68.0	68.0	68.0	68.0
Vapor press. VOC (mm Hg):	311.5	101.9	59.0	12.7	1.28	177.21	21.80	93.74	42.27
Molecular weight of VOC:	84.9	133.4	131.4	165.8	150.0	58.08		32.04	46.07
-----	-----	-----	-----	-----	-----	-----	-----	-----	-----
(1) Partial pressure air =	448.5	658.1	701.0	747.3	758.7	582.8	738.2	666.3	717.7
(2) Mole fraction of air =	0.590	0.866	0.922	0.983	0.998	0.767	0.971	0.877	0.944
(3) Pound-moles of air =	0.034	0.034	0.034	0.034	0.034	0.034	0.034	0.034	0.034
(4) Pound-moles, total =	0.058	0.040	0.037	0.035	0.035	0.045	0.036	0.039	0.037
(5) Pound-moles of VOC =	0.024	0.005	0.003	0.001	0.000	0.010	0.001	0.005	0.002
(6) Pounds of VOC =	2.03	0.71	0.38	0.10	0.01	0.61	0.00	0.16	0.09
(7) VOC CONC. PPM (VOL.) =	409,922	134,050	77,609	16,743	1,688	233,176	28,678	123,347	55,622
(8) VOC CONC. PPM (WT.) =	670,455	415,916	276,010	88,717	8,668	378,495	0	134,537	85,561





UNITED STATES ENVIRONMENTAL PROTECTION AGENCY

REGION IV

345 COURTLAND STREET, N.E.  
ATLANTA, GEORGIA 30365

MAY 09 1990

CERTIFIED MAIL  
RETURN RECEIPT REQUESTED

4WD-RCRA

Mr. Victor San Agustin, P.E.  
Hazardous Waste Section  
Division of Waste Management  
Florida Department of Environmental  
Regulation  
4520 Oak Fair Boulevard  
Tampa, Florida 33610-7347

D. E. R.  
MAY 11 1990  
SOUTHWEST DISTRICT  
TAMPA

RE: Final Draft HSWA Permit for Safety-Kleen Corporation's New  
Tampa Facility; EPA I.D. Number FLD 980 847 271

Dear Mr. San Agustin:

Enclosed is a copy of the final draft federal Hazardous and  
Solid Waste Amendments (HSWA) Permit addressing solid waste  
management units for the above referenced facility. No comments  
were received on the preliminary draft from the Florida  
Department of Environmental Regulation (FDER) or Safety-Kleen  
Corporation.

Please advise us by telephone when the public notice of the  
Draft RCRA Permit become effective. Please send the EPA a copy  
of the public notice when it is received from the facility.

If you have any questions regarding the enclosed materials,  
please contact Mr. Hugh Hazen of my staff at (404) 347-3433.

Sincerely yours,

James H. Scarbrough, P.E., Chief  
RCRA & Federal Facilities Branch  
Waste Management Division

Enclosure

cc: Satish Kastury, FDER, Tallahassee